



Automation for a Changing World

Delta Heavy Duty Vector Control Drive CH2000 Series



reddot design award
winner 2010

www.deltaww.com

 **DELTA**
Smarter. Greener. Together.

CH2000 Power in Hand

With years of experience and expertise in drive technology, Delta presents its new AC motor drive, the CH2000 Series, providing high performance with robust design. It is equipped with larger starting torque and high overload capabilities to fulfill the needs of heavy load applications and to handle sudden load impact conditions.

The CH2000 Series is designed with high tolerance for critical environments, especially for heavy load applications. Featuring outstanding controls for all fields and system performance improvements, the CH2000 Series offers exceptional quality and comprehensive services.

Introducing the CH2000 Series heavy load field-oriented vector control drive to enhance your competitive advantage for achieving greater success.





Table of Contents

Functions and Applications

3

- Standard Models
 - Excellent Drive Control
 - Excellent Overload Capability
 - Fast Response to Load Impact
 - Large Starting Torque
- Flexible Torque and Current Limit Settings
 - Deceleration Energy Backup (DEB)
- Industrial Applications
 - Modular Design
 - High-Speed Network
 - Intelligent PLC Functions
- Permanent Magnet (PM) Motor Applications
 - Excellent Environment Adaptability

Specifications

12

- Environment for Operation, Storage and Transportation
 - Operation Temperature and Protection Level
 - Product Specifications
 - General Specifications

Wiring

15

Dimensions

17

Option Cards

26

Ordering Information

31

Model Name Explanation

32

Attention

33

Standard Models (IP20/NEMA1)

Power range: 230V 0.75~75 kW, 460V 0.75~280 kW

230V (kW)	0.75	1.5	2.2	3.7	5.5	7.5	11	15	18.5	22	30	37	45	55	75		
230V (HP)	1	2	3	5	7.5	10	15	20	25	30	40	50	60	75	100		
Output (A)	5	8	11	17	25	33	49	65	75	90	120	146	180	215	255		
Frame Size	A				B			C		D			E		F		
Braking Chopper	Built-in										Optional						
DC Reactor	Optional										Built-in						
EMC Filter	Optional																
Protection Level	21 (IP20, NEMA1)										00 (IP00, UL Open Type)/ 21 (IP20, NEMA1)						
460V (kW)	0.75	1.5	2.2	3.7	5.5	7.5	11	15	18.5	22	30	37	45	55	75	90	110
460V (HP)	1	2	3	5	7.5	10	15	20	25	30	40	50	60	75	100	125	150
Output (A)	3	4	6	9	12	18	24	32	38	45	60	73	91	110	150	180	220
Frame Size	A					B			C			D0		D		E	
Braking Chopper	Built-in										Optional						
DC Reactor	Optional										Built-in						
EMC Filter	Built-in (CH4EA Models)										Optional						
Protection Level	21 (IP20, NEMA1)										00 (IP00, UL Open Type)						

Advanced Drive Controls

High Performance

1. Large starting torque
2. High overload capability
3. Super heavy duty setting
4. Fast response to load impact
5. A drive for both asynchronous and synchronous motors

Flexible Applications

1. Control modes for speed, torque, position and synchronous control
2. Built-in PLC functions
3. Excellent 4-quadrant torque control and limit
4. Noise reduction operation



132	160	185	220	280
175	215	250	300	375
250	310	370	440	550
F	G		H	

al
n
al
) /21 (IP20, NEMA1)



Modular Design

1. Hot pluggable LCD keypad
2. I/O extension card options
3. PG card options
4. Network cards for fieldbus modules
5. Removable fan

Adaptability to Critical Environments

1. 50°C operating temperature
2. Built-in DC reactor*
3. Coated circuit boards
4. Built-in EMC filter*
5. International safety standard (CE/UL/cUL)

*Note: Please refer to product specifications for more details



Excellent Overload Capability

The super heavy duty setting is suitable for harsh environment applications with a current overload capability of 150% for 60 seconds and 200% for 3 seconds.

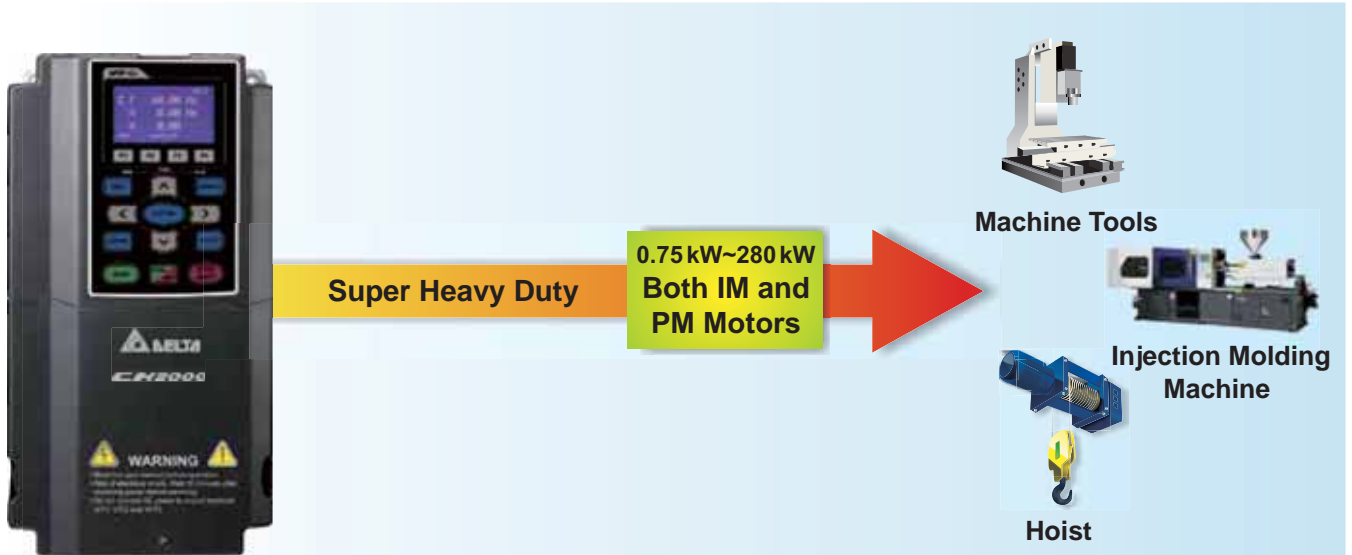

Fast Response to Load Impact

Response to sudden load impact

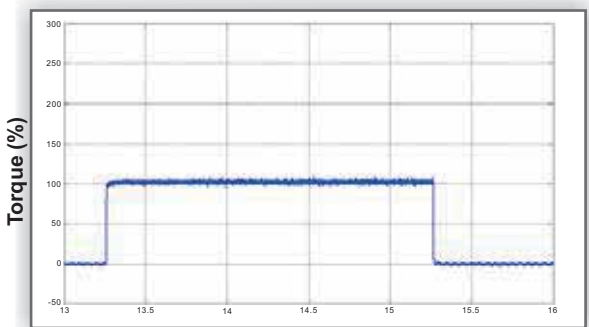
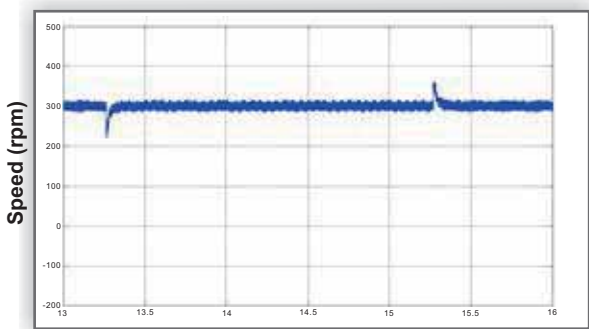

Large Starting Torque

Large starting torque output up to 200% at very low speed under FOC + PG mode.

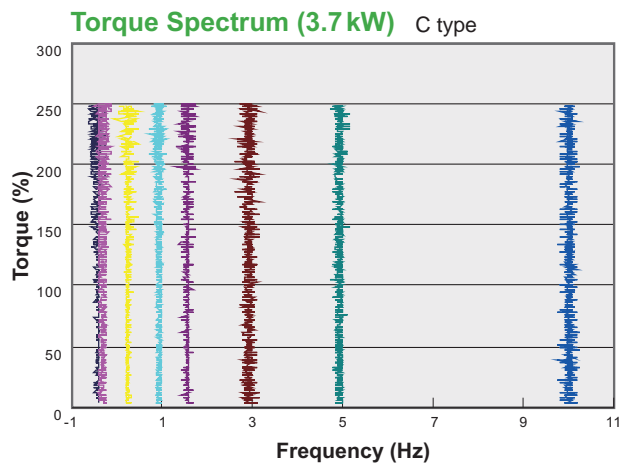

Flexible Torque and Current Limit Settings

Prevents equipment damage from load impact. When the drive is in FOC control mode, setting torque limit can protect the machinery under many conditions.

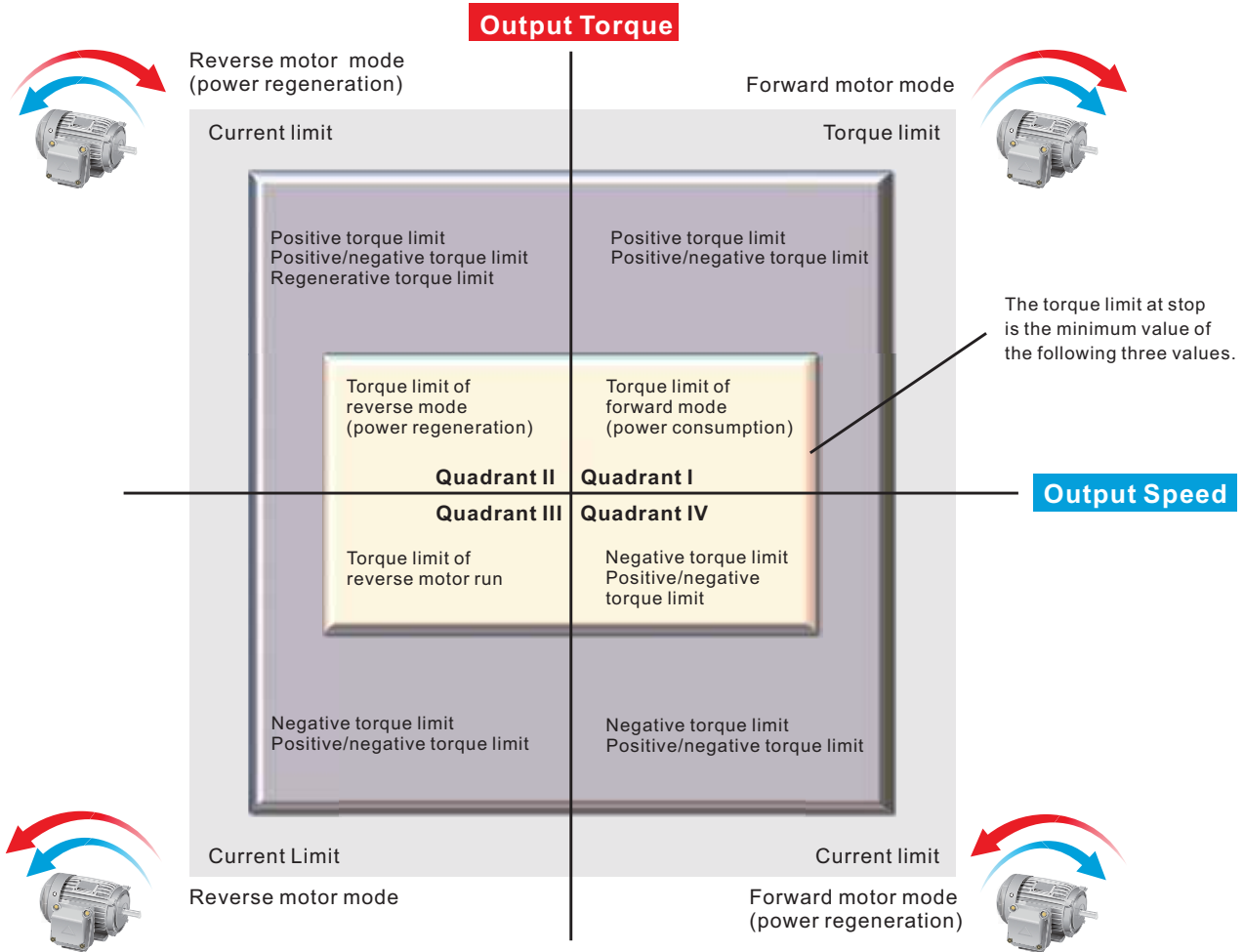

Deceleration Energy Backup (DEB)

Controls the motor's deceleration to a stop when a sudden power outage occurs and accelerates it to its previous operation speed when power returns.

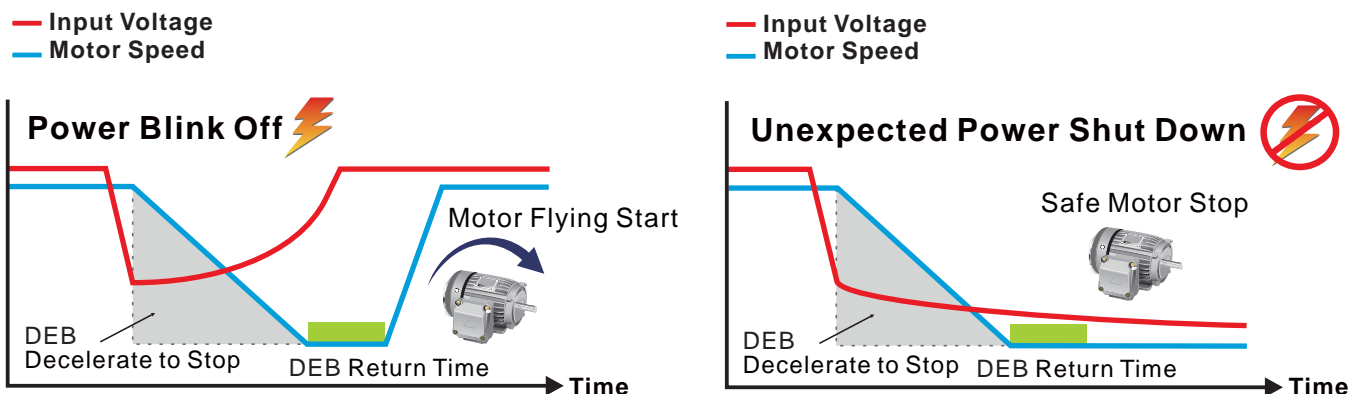

Industrial Applications

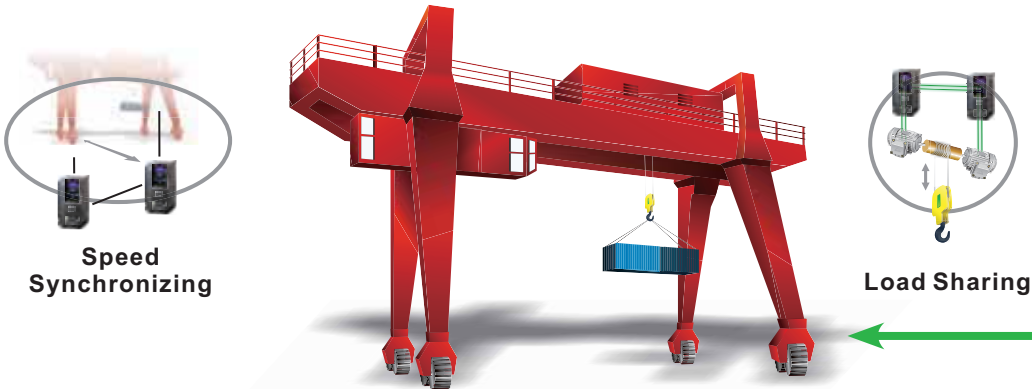

Delta Power Regenerative Unit REG2000 Series



Provides the crane and hoist system four-quadrant operation and energy saving performance with the power regeneration function.



CNC Application (C-axis)



The CH2000 provides position control and pulse wave velocity following functions for C-axis applications with high overload capability providing excellent performance for high-speed rigid tapping

Delta Active Front End AFE2000 Series



Provides the crane and hoist system excellent operation quality with reduced torque ripple, harmonic suppression, high power factors and energy saving performance with the power regeneration function.

Advanced Crane Function

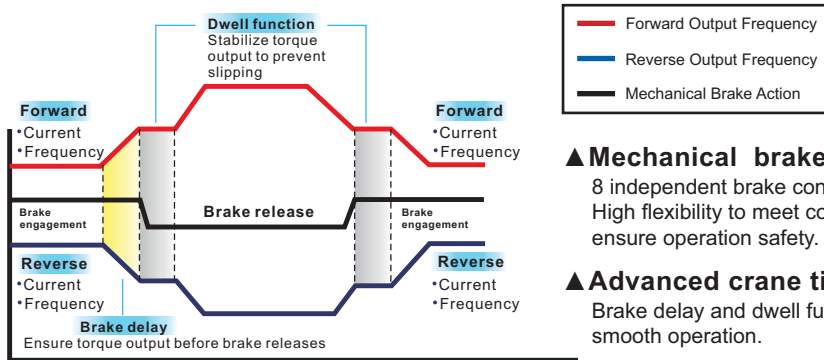

▲ Mechanical brake control

8 independent brake control setting to different criteria. High flexibility to meet complex application needs and ensure operation safety.

▲ Advanced crane time sequence

Brake delay and dwell function ensure smooth operation.

Fast Response to Load Impact

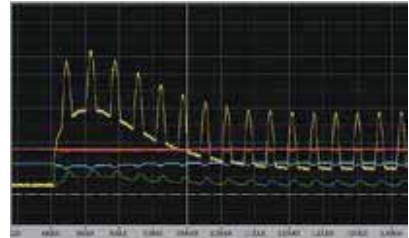
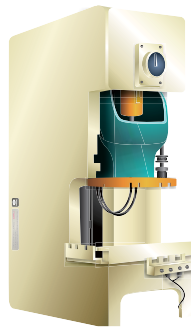

High endurance. Maintains a stable DC bus voltage when load impact occurs.

Tension Control



Torque Ripple

Other Delta Products

CH2000

CH2000+AFE2000

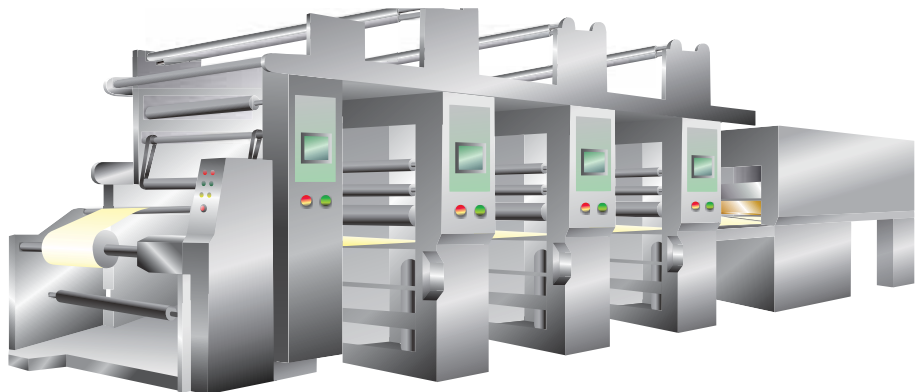

Modular Design

Modular design for high flexibility for system design and maintenance. Various accessories are available such as I/O extension cards, encoder feedback cards, communication cards, a hot pluggable LCD keypad, removable terminals and a removable fan.

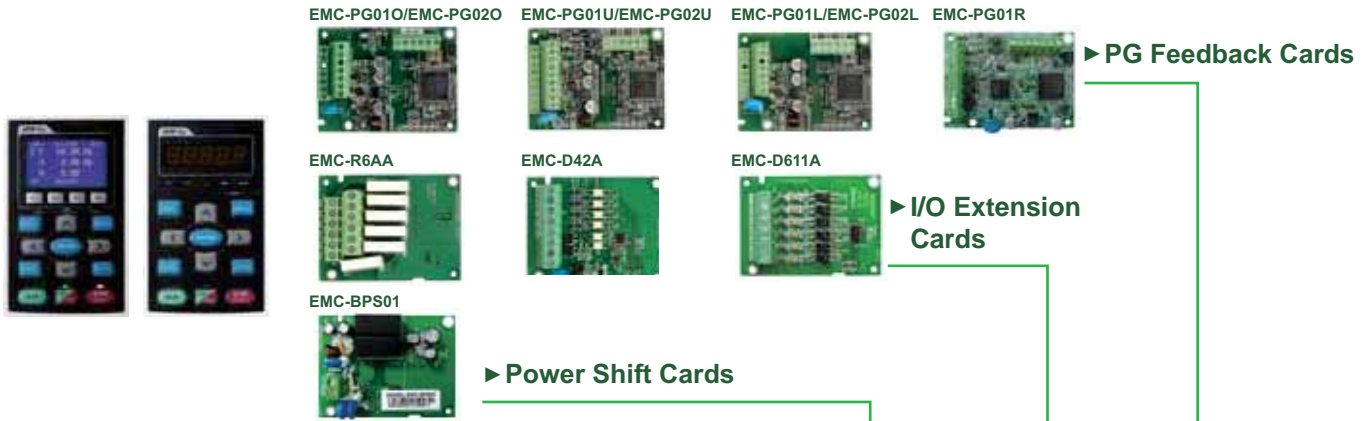

- KPC-CC01 keypad
- Standard RJ45 network cable for remote operation
- Easy to remove with one press



■ Remove the safety screws and press on both side tabs to remove the cover



■ Modular fan design is easy to clean and replace to provide longer service life



■ The product nameplate shows input/output voltage, input/output current, frequency range, and more

Removable terminals

Easy to wire with high safety

Analog I/O switch



Termination resistor



Dual RJ45 communication ports



CMC-PD01



CMC-DN01



CMC-MOD01
CMC-EIP01



EMC-COP01



High-Speed Network

- Provides optional MODBUS RTU and various fieldbus cards for flexible communication applications
- Advanced network functions
- Built-in MODBUS communication interface
- **CANopen (DS402)**



Ability to control up to 8 Slave drives via the CANopen Master function

- Supports all Delta industrial automation products (Built-in EDS files for all Delta industrial automation products)
- I/O data configurations for each device on the CANopen network
- Motion control planning function
- WPL Soft

- TAP-CN03 distribution box for long distances

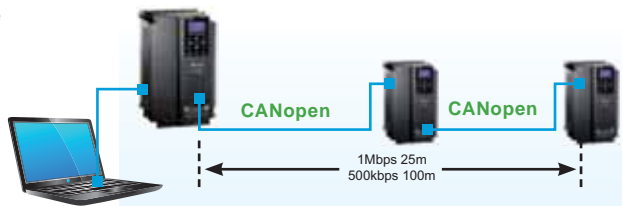

- RJ45 cable



■ DeviceNet

Through the Delta specially designed DeviceNet Builder software, users can easily establish a standard DeviceNet control network by the parameter pre-assignment function for each device and remote I/O.

- Supports all Delta industrial automation products (Built-in EDS files for all Delta industrial automation products)
- I/O data configurations for each device on the DeviceNet network
- DeviceNet layout software



■ EtherNet/IP

■ MODBUS TCP

Delta provides communication integrator software that offers graphic module settings and a user friendly interface to support all Ethernet products settings and online monitoring.

- Delta software for Ethernet/MODBUS TCP products
- Graphic module setting and a user friendly interface
- Auto search function
- Supports Virtual COM settings



Intelligent PLC Functions

- Built-in 10K steps capacity of PLC functions. Distributed control and independent operation are easily achieved via network connection.
- CANopen Master protocol and PLC functions provide synchronous control and fast data exchange.

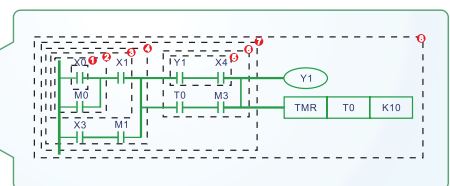
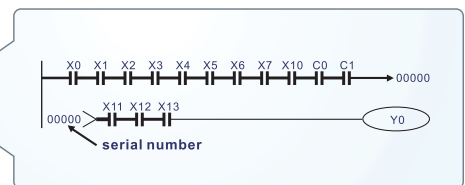

A Drive for Permanent Magnet (PM) Motors

The CH2000 Series can control both induction and permanent magnet (PM) motors. The benefits of using PM motors include dynamic response and precise position/speed/torque control.

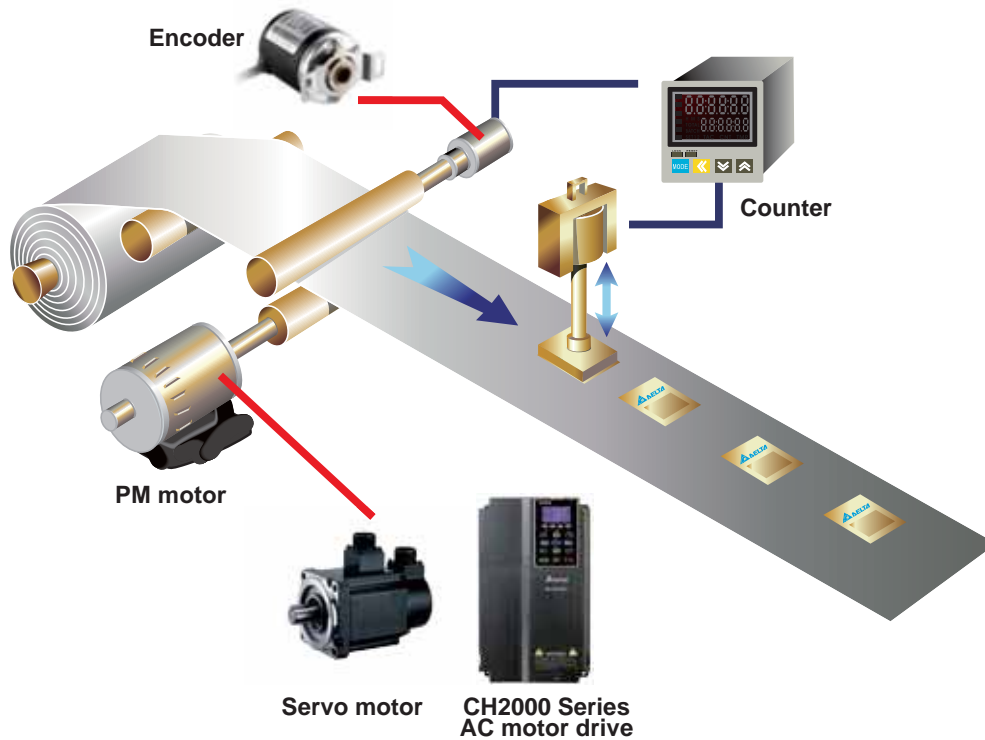

Excellent Environment Adaptability

- Built-in DC choke*
- Built-in EMC filter
- Enhanced conformal coating on PCBs for safe operation in harsh environment applications
- Isolation design of heat dissipation system separate from other drive components
- There are two heat dissipating methods:
 - (1) Flange mounting method helps disperse heat out of the drive
 - (2) Cooling fan design fan provides cold air to the aluminum heat sink.

Both methods are efficient and provide users with flexible options according to their working environment needs.

*Note: Please refer to the Product Specification



Specifications

Environment for Operation, Storage and Transportation

DO NOT expose the AC motor drive to harsh environments, such as dust, direct sunlight, corrosive/flammable gasses, humidity, liquid or vibrations. The salts in the air must be less than 0.01mg/cm² per year.

Environment	Installation Location	IEC60364-1/IEC60664-1 Pollution degree 2, indoor use only		
	Surrounding Temperature	Storage/Transportation	-25°C ~ +70°C	
		Only allowed at non-condensation, non-frost, non-conductive environment.		
	Rated Humidity	Operation	Max. 95%	
		Storage/Transportation	Max. 95%	
		No condense water		
	Air Pressure	Operation/Storage	86 to 106 kPa	
		Transportation	70 to 106 kPa	
	Pollution Level	IEC60721-3-3		
		Operation	Class 3C2; Class 3S2	
Storage		Class 1C2; Class 1S2		
Transportation		Class 2C2; Class 2S2		
Only allowed at non-condensation, non-frost, non-conductive environment.				
Altitude	Operation	If the AC motor drive is installed at an altitude 0 ~ 1000m, follow normal operation restriction. If it is install at altitude 1000 ~ 3000m, decrease 1% of rated current or lower 0.5°C of temperature for every 100m increase in altitude. Maximum altitude for Corner Grounded TN system is 2000m; for application over 2000m, please contact Delta for more details.		
Package Drop	Storage/Transportation	ISTA procedure 1A(according to weight) IEC60068-2-31		
Vibration	1.0 mm, peak to peak value range from 2Hz to 13.2 Hz; 0.7G ~ 1.0G range from 13.2 Hz to 55Hz; 1.0G range from 55Hz to 512 Hz. Comply with IEC 60068-2-6.			
Impact	IEC/EN 60068-2-27			
Operation Position	Max. allowed offset angle ±10° (under normal installation position)			

Operation Temperature and Protection Level

Model	Frame	Top Cover	Conduit Box	Protection Level	Operation Temperature
VFDxxxCHxxx-21	Frame A ~ C 230 V: 0.75 ~ 18.5 kW 460 V: 0.75 ~ 30 kW	Remove top cover	Standard conduit plate	IP20/UL Open Type	SHD: -10°C ~ 50°C
		Standard with top cover		IP20/UL Type1/NEMA1	SHD: -10°C ~ 40°C
	Frame D ~ H 230 V: 22 kW and above 460 V: 37 kW and above	N/A	Conduit box	IP20/UL Type1/NEMA1	SHD: -10°C ~ 40°C
VFDxxxCHxxx-00	Frame D ~ H 230 V: 22 kW and above 460 V: 37 kW and above	N/A	Without standard conduit box	IP00 IP20/UL Open Type 	SHD: -10°C ~ 50°C

Protection degree for the circled area is IP00, other areas are IP20

Specifications



230V																		
Frame Size		A				B			C		D			E		F		
Model VFD-□□□ CH23A-□□		007	015	022	037	055	075	110	150	185	220	300	370	450	550	750		
Applicable Motor Output (kW)		0.75	1.5	2.2	3.7	5.5	7.5	11	15	18.5	22	30	37	45	55	75		
Applicable Motor Output (hp)		1	2	3	5	7.5	10	15	20	25	30	40	50	60	75	100		
Output Rating	HEAVY DUTY	Rate Output Capacity (kVA)		2.0	3.2	4.4	6.8	10	13	20	26	30	36	48	58	72	86	102
		Rated Output Current (A)		5	8	11	17	25	33	49	65	75	90	105	146	180	215	255
		Carrier Frequency (kHz)		5 ~ 15kHz														
		Overload Tolerance		150% of rated current: 1 minute for every 5 minutes 200% of rated current: 3 seconds for every 30 seconds														
Input Rating	Input Current (A) Super Heavy Duty		6.4	12	16	20	28	36	52	72	83	99	124	143	171	206	245	
	Rated Voltage/Frequency		3-phase AC 200V ~ 240V (-15% ~ +10%), 50/60Hz															
	Operating Voltage Range		170 ~ 265V _{AC}															
	Frequency Tolerance		47 ~ 63Hz															
AC Drive Weight		2.6±0.3Kg				5.4±1Kg			9.8±1.5Kg		38.5±1.5Kg			64.8±1.5Kg		86.5±1.5Kg		
Cooling Method		Natural cooling	Fan cooling															
Braking Chopper		Frame A to C (built-in); Frame D and above (optional)																
DC Reactor		Frame A to C (optional); Frame D and above (built-in)																
EMC Filter		Optional																
EMC-COP01		Optional																

460V														
Frame Size		A					B			C				
Model VFD-□□□ CH43□-□□		007	015	022	037	055	075	110	150	185	220	300		
Applicable Motor Output (kW)		0.75	1.5	2.2	3.7	5.5	7.5	11	15	18.5	22	30		
Applicable Motor Output (hp)		1	2	3	5	7.5	10	15	20	25	30	40		
Output Rating	SUPER HEAVY DUTY	Rate Output Capacity (kVA)		2.0	3.2	4.8	7.2	9.6	14	19	25	30	36	48
		Rated Output Current (A)		3	4	6	9	12	18	24	32	38	45	60
		Carrier Frequency (kHz)		5 ~ 15kHz										
		Overload Tolerance		150% of rated current: 1 minute for every 5 minutes 200% of rated current: 3 seconds for every 30 seconds										
Input Rating	Input Current (A) Super Heavy Duty		4.3	5.9	8.7	14	17	20	26	35	40	47	63	
	Rated Voltage/Frequency		3-phase AC 380V ~ 480V (-15% ~ +10%), 50/60Hz											
	Operating Voltage Range		323 ~ 528V _{AC}											
	Frequency Tolerance		47 ~ 63Hz											
AC Drive Weight		2.6±0.3Kg					5.4±1Kg			9.8±1.5Kg				
Cooling Method		Natural cooling	Fan cooling											
Braking Chopper		Frame A to C (built-in); Frame D and above (optional)												
DC Reactor		Frame A to C (optional); Frame D and above (built-in)												
EMC Filter		Frame A ~ C, VFD□□□□CH4EA-21, EMC filter built-in Frame A ~ C, VFD□□□□CH43A-21, No EMC filter												
EMC-COP01		Optional												

460V

Frame Size	D0	D			E		F	G			H	
Model VFD-□□□□CH43□-□□	370	450	550	750	900	1100	1320	1600	1850	2200	2800	
Applicable Motor Output (kW)	37	45	55	75	90	110	132	160	185	220	280	
Applicable Motor Output (hp)	50	60	75	100	125	150	175	215	250	300	375	
Output Rating SUPER HEAVY DUTY	Rate Output Capacity (kVA)	58	73	88	120	143	175	199	247	295	359	438
	Rated Output Current (A)	73	91	110	150	180	220	250	310	370	440	550
	Carrier Frequency (kHz)	5 ~ 15 kHz										
	Overload Tolerance	150% of rated current: 1 minute for every 5 minutes 200% of rated current: 3 seconds for every 30 seconds										
Input Rating	Input Current (A) Super Heavy Duty	74	101	114	157	167	207	240	300	380	400	494
	Rated Voltage/Frequency	3 Phase AC 380V ~ 480V (-15% ~ +10%), 50/60Hz										
	Operating Voltage Range	323 ~ 528V _{ac}										
	Frequency Tolerance	47 ~ 63Hz										
AC Drive Weight	38.5 ± 1.5Kg			64.8 ± 1.5Kg		86.5 ± 1.5Kg		134 ± 4 Kg			257 ± 12Kg	
Cooling Method	Fan cooling											
Braking Chopper	Frame D and above (optional)											
DC Reactor	Frame D and above (built-in)											
EMC Filter	Frame D and above (Optional)											
EMC-COP01	Optional											

General Specifications

Control Characteristics	Control Method	1: V/F, 2: SVC, 3: VF+PG, 4: FOC+PG, 5: TQC+PG,
	Starting Torque	Reach up to 200% or above at 0.5Hz. Under FOC+PG mode, starting torque can reach 200% at 0Hz.
	V/F Curve	4 point adjustable V/F curve and square wave
	Speed Response Ability	5Hz (vector control can reach up to 40Hz)
	Torque Limit	Super heavy duty 220% torque current
	Torque Accuracy at TQC Mode	±5%
	Max. Output Frequency (Hz)	Super Heavy Duty: 0.00 ~ 599.00Hz
	Frequency Output Accuracy	Digital command: 0.01%, -10°C ~ +40°C, Analog command: 0.1%, 25 ± 10°C
	Output Frequency Resolution	Digital command: 0.01Hz, Analog command: 0.03 X Max. output frequency/60Hz (± 11 bit)
	Overload Tolerance	Rated output current is 150 % for 60 seconds/Rated output current is 200% for 3 seconds
Frequency Setting Signal	+10V ~ -10, 0 ~ +10V, 4 ~ 20mA, 0 ~ 20mA, Pulse input	
Accel./decel. Time	0.00 ~ 600.00/0.0 ~ 6000.0 seconds	
Main Control Function	Torque control, Droop control, Speed/torque control switching, Feed forward control, Zero-servo control, Momentary power loss ride thru, Speed search, Over-torque detection, Torque Limit, 17-step speed (Max.), Accel./decel time switch, S-curve accel./decel, 3-wire sequence, Auto-Tuning (rotational, stationary), Dwell, Cooling fan on/off switch, Slip compensation, Torque compensation, JOG frequency, Frequency upper/lower limit settings, DC injection braking at start/stop, High slip braking, PID control (with sleep function), Energy saving control, MODBUS communication (RS-485 RJ45, Max.115.2 kbps), Fault restart, Parameter copy	
Fan Control	230V model: VFD150CH23A-21(include) and series above: PMW control VFD110CH23A-21(include) and series below: on/off switch control 460V model: VFD185CH43A/4EA-21(include) and series above: PMW control VFD150CH43A/4EA-21(include) and series below: on/off switch control	
Protection Characteristics	Motor Protection	Electronic thermal relay protection
	Over-current Protection	For drive model 230V and 440V over-current protection for 300% rated current ; current clamp (Super heavy duty: 220%)
	Over-Voltage Protection	230: drive will stop when DC-BUS voltage exceeds 410V 460: drive will stop when DC-BUS voltage exceeds 820V
	Over-Temperature Protection	Built-in temperature sensor
	Stall Prevention	Stall prevention during acceleration, deceleration and running independently
	Restart after Instantaneous Power Failure	Parameter setting up to 20 seconds
	Grounding Leakage Current Protection	Leakage current is higher than 50% of rated current of the AC motor drive
International Certifications	  GB/T12668-2 	

Wiring

Frame A ~ C

Input: 3-phase power

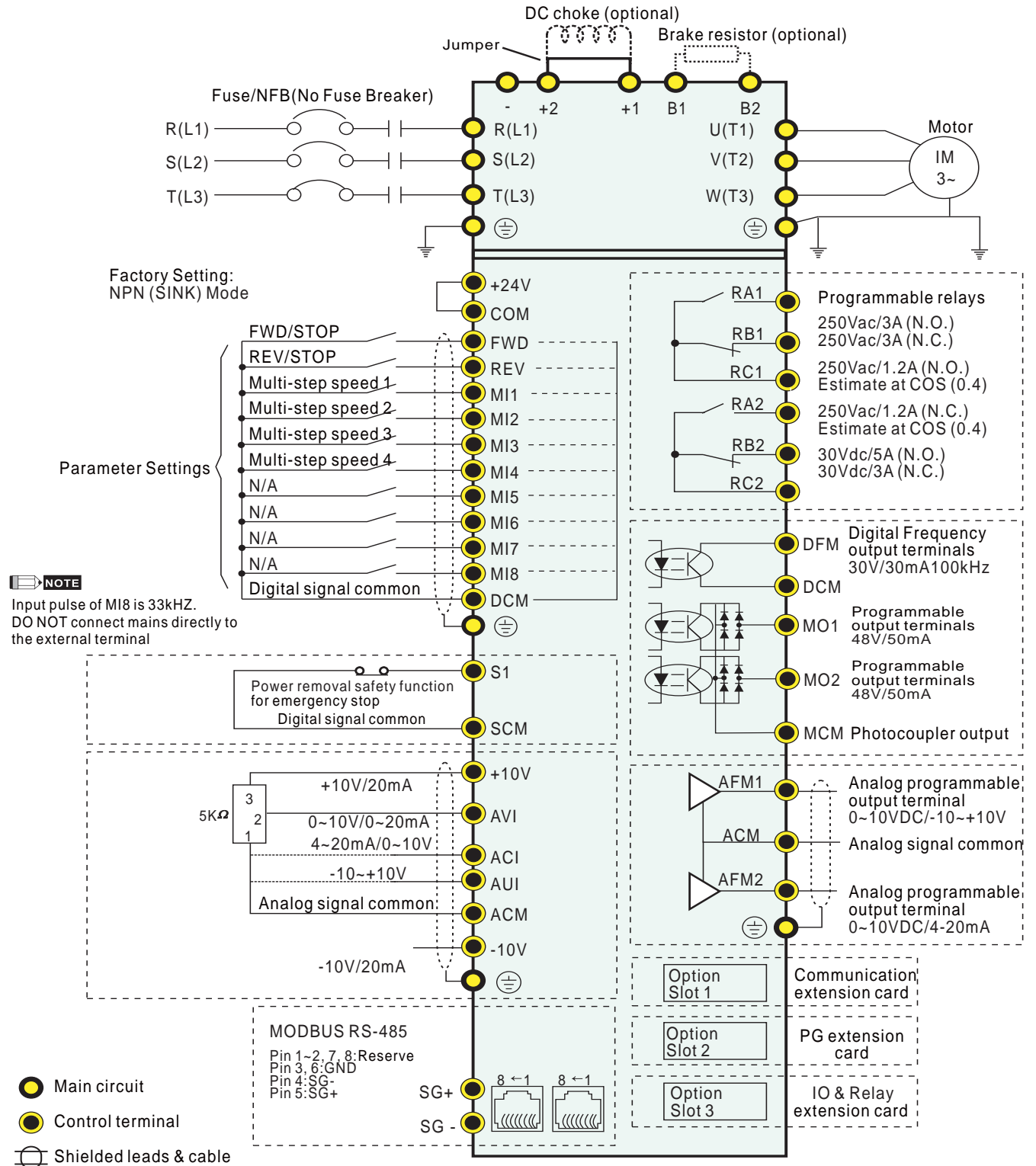

Frame G and H
Input: 3-phase power

Frame D and for frames above
Input: 3-phase power

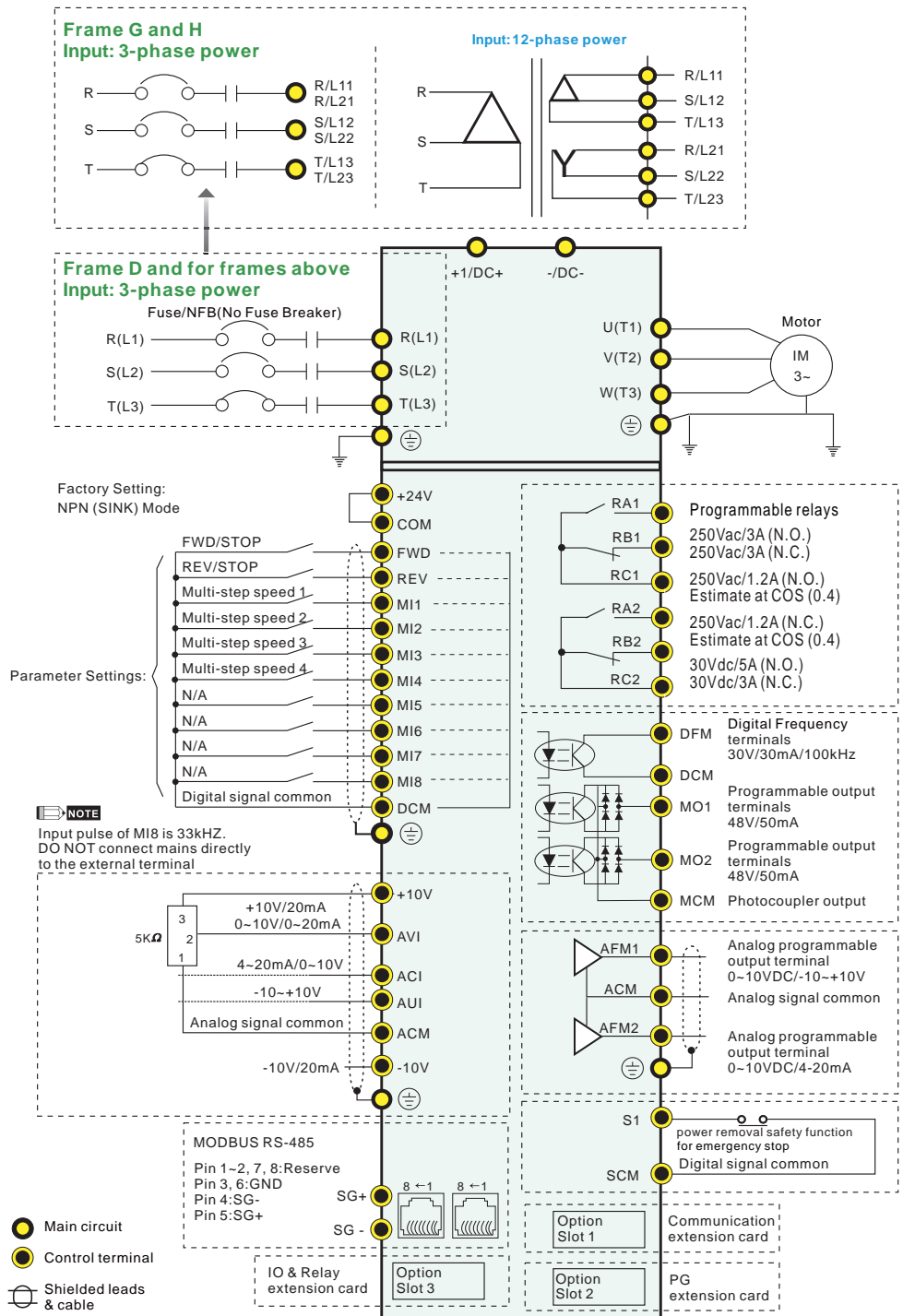

Dimensions

Digital Keypad

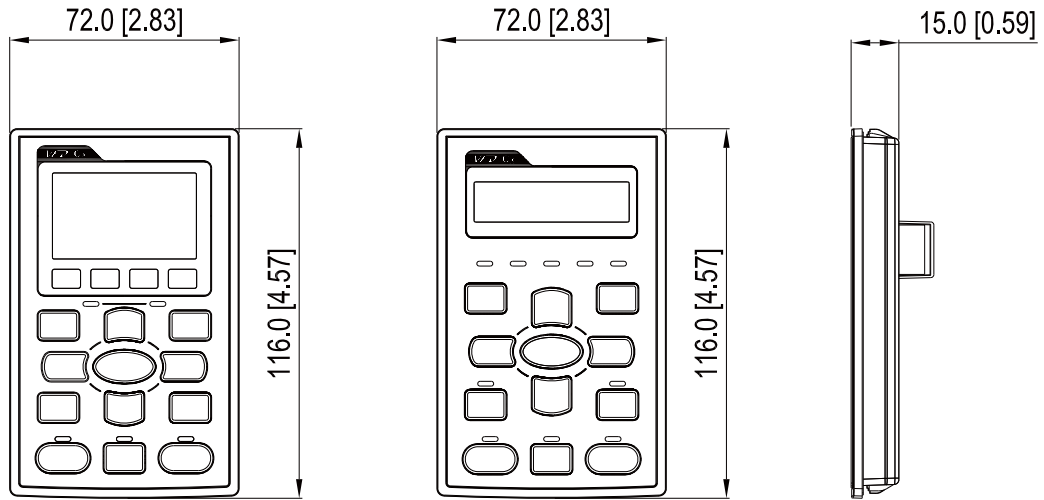

KPC-CC01

Standard LCD Digital Keypad

KPC-CE01

Optional LED Digital Keypad

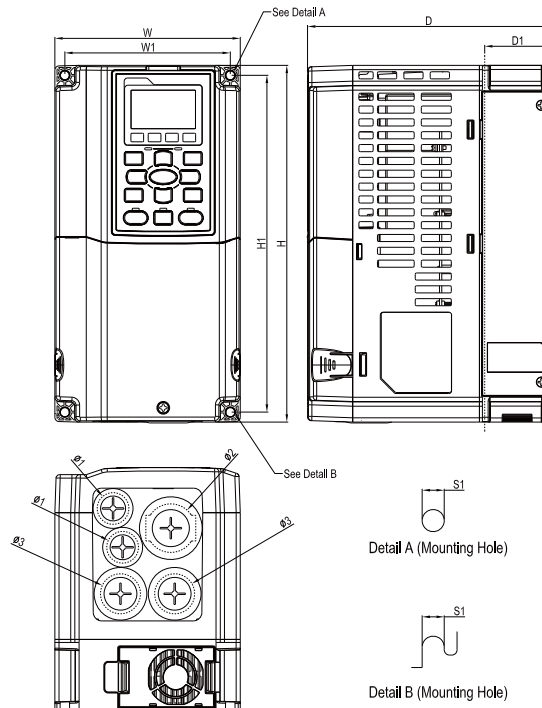

MODEL

VFD007CH23A-21	VFD055CH43A-21
VFD015CH23A-21	VFD007CH4EA-21
VFD022CH23A-21	VFD015CH4EA-21
VFD037CH23A-21	VFD022CH4EA-21
VFD007CH43A-21	VFD037CH4EA-21
VFD015CH43A-21	VFD055CH4EA-21
VFD022CH43A-21	
VFD037CH43A-21	

Frame	W	H	D	W1	H1	D1*	S1	Ø1	Ø2	Ø3	
A	mm	130.0	250.0	170.0	116.0	236.0	45.8	6.2	22.2	34.0	28.0
	inch	5.12	9.84	6.69	4.57	9.29	1.80	0.24	0.87	1.34	1.10

D1*: Flange mount

Frame B

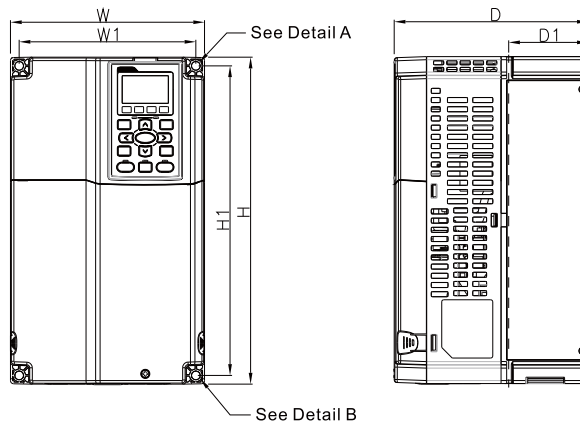

MODEL

VFD055CH23A-21
 VFD075CH23A-21
 VFD110CH23A-21
 VFD075CH43A-21
 VFD110CH43A-21
 VFD150CH43A-21
 VFD075CH4EA-21
 VFD110CH4EA-21
 VFD150CH4EA-21

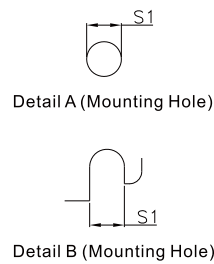
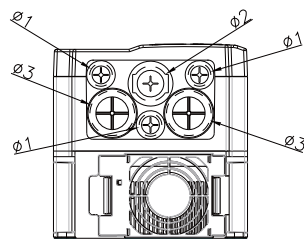

Frame		W	H	D	W1	H1	D1*	S1	Ø1	Ø2	Ø3
B	mm	190.0	320.0	190.0	173.0	303.0	77.9	8.5	22.2	34.0	43.8
	inch	7.48	12.6	7.48	6.81	11.93	3.07	0.33	0.87	1.34	1.72

D1*: Flange mount

Frame C

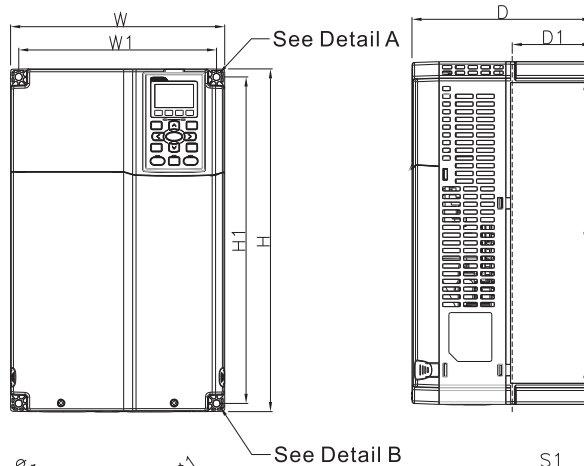

MODEL

VFD150CH23A-21
 VFD185CH23A-21
 VFD185CH43A-21
 VFD220CH43A-21
 VFD300CH43A-21
 VFD185CH4EA-21
 VFD220CH4EA-21
 VFD300CH4EA-21

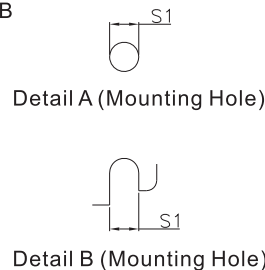
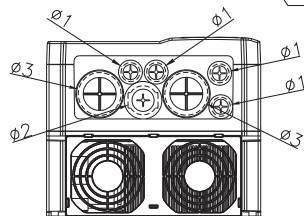

Frame		W	H	D	W1	H1	D1*	S1	Ø1	Ø2	Ø3
C	mm	250.0	400.0	210.0	231.0	381.0	92.9	8.5	22.2	34.0	50.0
	inch	9.84	15.75	8.27	9.09	15.00	3.66	0.33	0.87	1.34	1.97

D1*: Flange mount

Dimensions

Frame D1

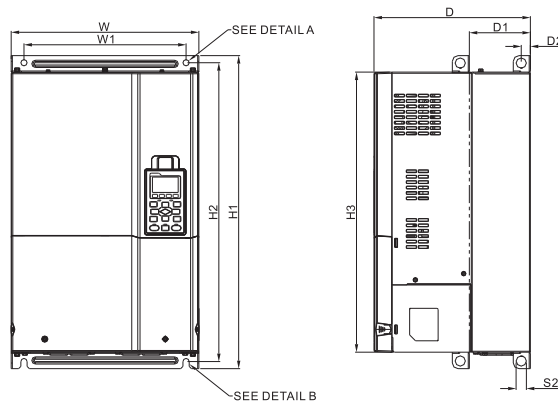

MODEL

VFD220CH23A-00
 VFD300CH23A-00
 VFD370CH23A-00
 VFD450CH43A-00
 VFD550CH43A-00
 VFD750CH43A-00

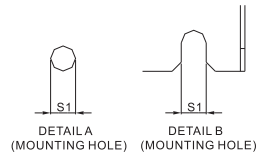
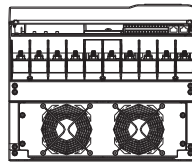

Frame	W	H	D	W1	H1	H2	H3	D1*	D2	S1	S2	Ø1	Ø2	Ø3	
D1	mm	330.0	-	275.0	285.0	550.0	525.0	492.0	107.2	16.0	11.0	18.0	-	-	-
	inch	12.99	-	10.83	11.22	21.65	20.67	19.37	4.22	0.63	0.43	0.71	-	-	-

D1*: Flange mount

Frame D2, D0-2

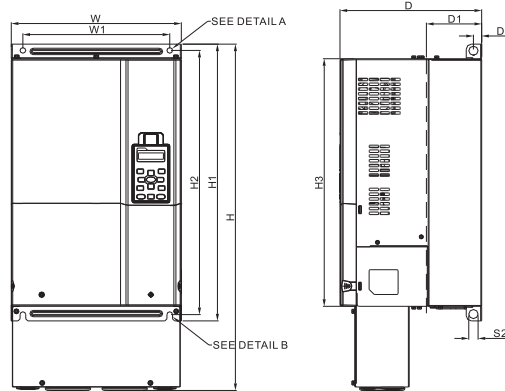

MODEL

Frame D2	Frame D0-2
VFD220CH23A-21	VFD370CH43S-21
VFD300CH23A-21	
VFD370CH23A-21	
VFD450CH43A-21	
VFD550CH43A-21	
VFD750CH43A-21	

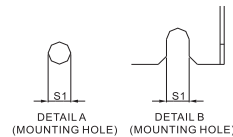
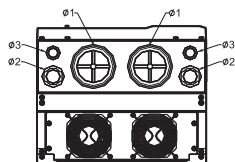

Frame	W	H	D	W1	H1	H2	H3	D1*	D2	S1	S2	Ø1	Ø2	Ø3	
D2	mm	330.0	688.3	275.0	285.0	550.0	525.0	492.0	107.2	16.0	11.0	18.0	76.2	34.0	22.0
	inch	12.99	27.10	10.83	11.22	21.65	20.6	19.37	4.22	0.63	0.43	0.71	3.00	1.34	0.87
D0-2	mm	330.0	614.4	255.0	235.0	500.0	475.0	442.0	94.2	16.0	11.0	18.0	62.7	34.0	22.0
	inch	12.99	24.19	10.04	9.25	16.69	18.70	17.40	3.71	0.63	0.43	0.71	2.47	1.34	0.87

D1*: Flange mount

Frame E1

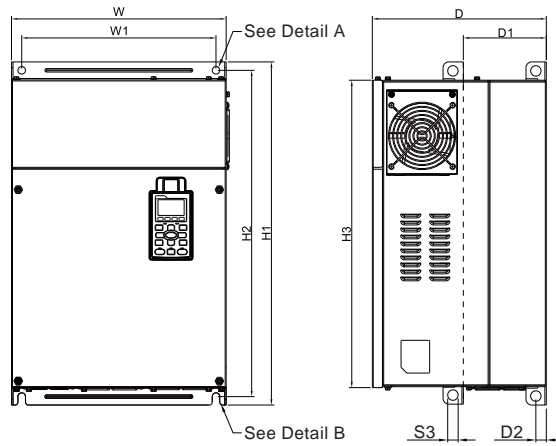

MODEL

- VFD450CH23A-00
- VFD550CH23A-00
- VFD900CH43A-00
- VFD1100CH43A-00

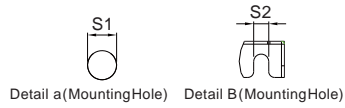
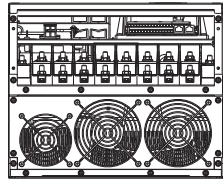

Frame		W	H	D	W1	H1	H2	H3	D1*	D2	S1/S2	S3	Ø1	Ø2	Ø3
E1	mm	370.0	-	300.0	335.0	589.0	560.0	528.0	143.0	18.0	13.0	18.0	-	-	-
	inch	14.57	-	11.81	13.19	23.19	22.05	20.80	5.63	0.71	0.51	0.71	-	-	-

D1*: Flange mount

Frame E2

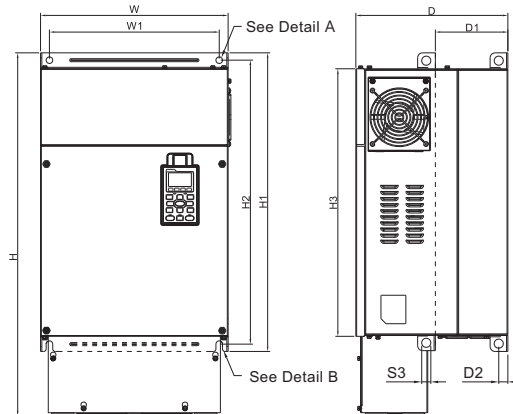

MODEL

- VFD450CH23A-21
- VFD550CH23A-21
- VFD900CH43A-21
- VFD1100CH43A-21

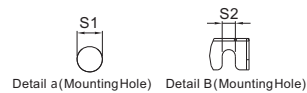
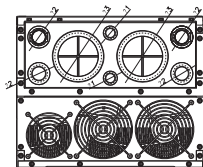

Frame		W	H	D	W1	H1	H2	H3	D1*	D2	S1/S2	S3	Ø1	Ø2	Ø3
E2	mm	370.0	715.8	300.0	335.0	589.0	560.0	528.0	143.0	18.0	13.0	18.0	22.0	34.0	92.0
	inch	14.57	28.18	11.81	13.19	23.19	22.05	20.80	5.63	0.71	0.51	0.7	0.87	1.34	3.62

D1*: Flange mount

Dimensions

Frame F1

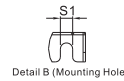
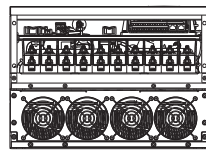
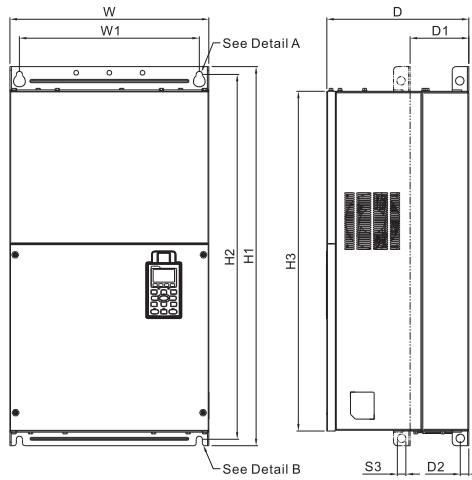

MODEL

VFD750CH23A-00
VFD1320CH43A-00

Frame		W	H	D	W1	H1	H2	H3	D1*	D2	S1	S2	S3	Ø1	Ø2	Ø3
F1	mm	420.0	-	300.0	380.0	800.0	770.0	717.0	124.0	18.0	13.0	25.0	18.0	-	-	-
	inch	16.54	-	11.81	14.96	31.50	30.32	28.23	4.88	0.71	0.51	0.98	0.71	-	-	-

D1*: Flange mount

Frame F2

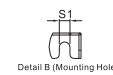
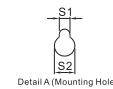
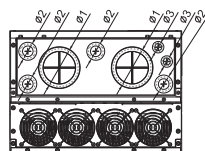
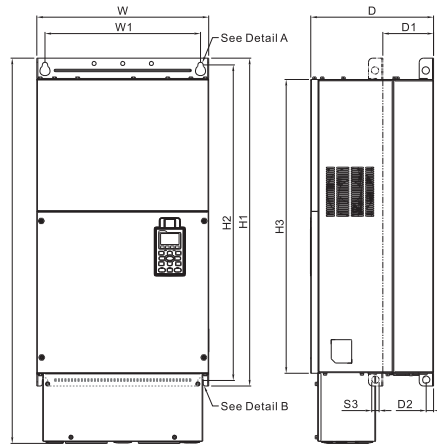

MODEL

VFD750CH23A-21
VFD1320CH43A-21

Frame		W	H	D	W1	H1	H2	H3	D1*	D2	S1	S2	S3	Ø1	Ø2	Ø3
F2	mm	420.0	940.0	300.0	380.0	800.0	770.0	717.0	124.0	18.0	13.0	25.0	18.0	92.0	35.0	22.0
	inch	16.54	37.00	11.81	14.96	31.5	30.32	28.23	4.88	0.71	0.51	0.98	0.71	3.62	1.38	0.87

D1*: Flange mount

Frame G1

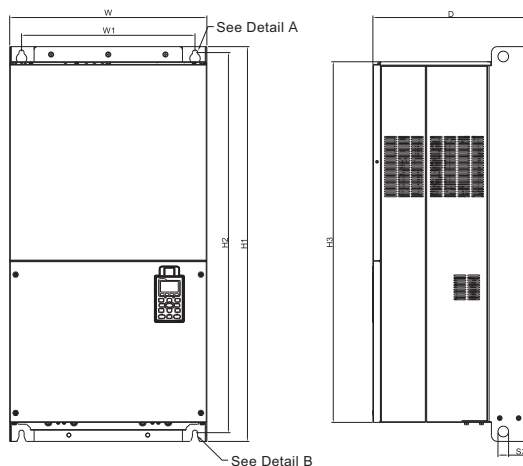

MODEL

VFD1600CH43A-00
VFD1850CH43A-00
VFD2200CH43A-00

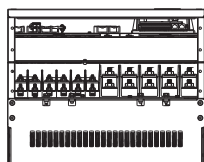

Detail a (MountingHole) Detail B (MountingHole)

Frame		W	H	D	W1	H1	H2	H3	S1	S2	S3	Ø1	Ø2	Ø3
G1	mm	500.0	-	397.0	440.0	1000.0	963.0	913.6	13.0	26.5	27.0	-	-	-
	inch	19.69	-	15.63	217.32	39.37	37.91	35.97	0.51	1.04	1.06	-	-	-

Frame G2

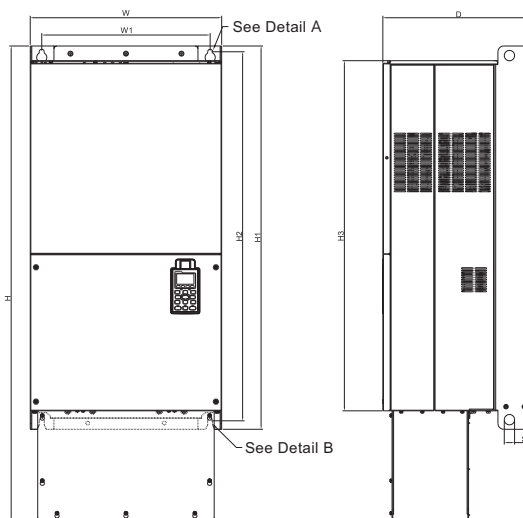

MODEL

VFD1600CH43A-21
VFD1850CH43A-21
VFD2200CH43A-21

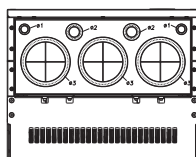

Detail a (MountingHole) Detail B (MountingHole)

Frame		W	H	D	W1	H1	H2	H3	S1	S2	S3	Ø1	Ø2	Ø3
G2	mm	500.0	1240.2	397.0	440.0	1000.0	963.0	913.6	13.0	26.5	27.0	22.0	34.0	117.5
	inch	19.69	48.83	15.63	217.32	39.37	37.91	35.97	0.51	1.04	1.06	0.87	1.34	4.63

Dimensions

Frame H1

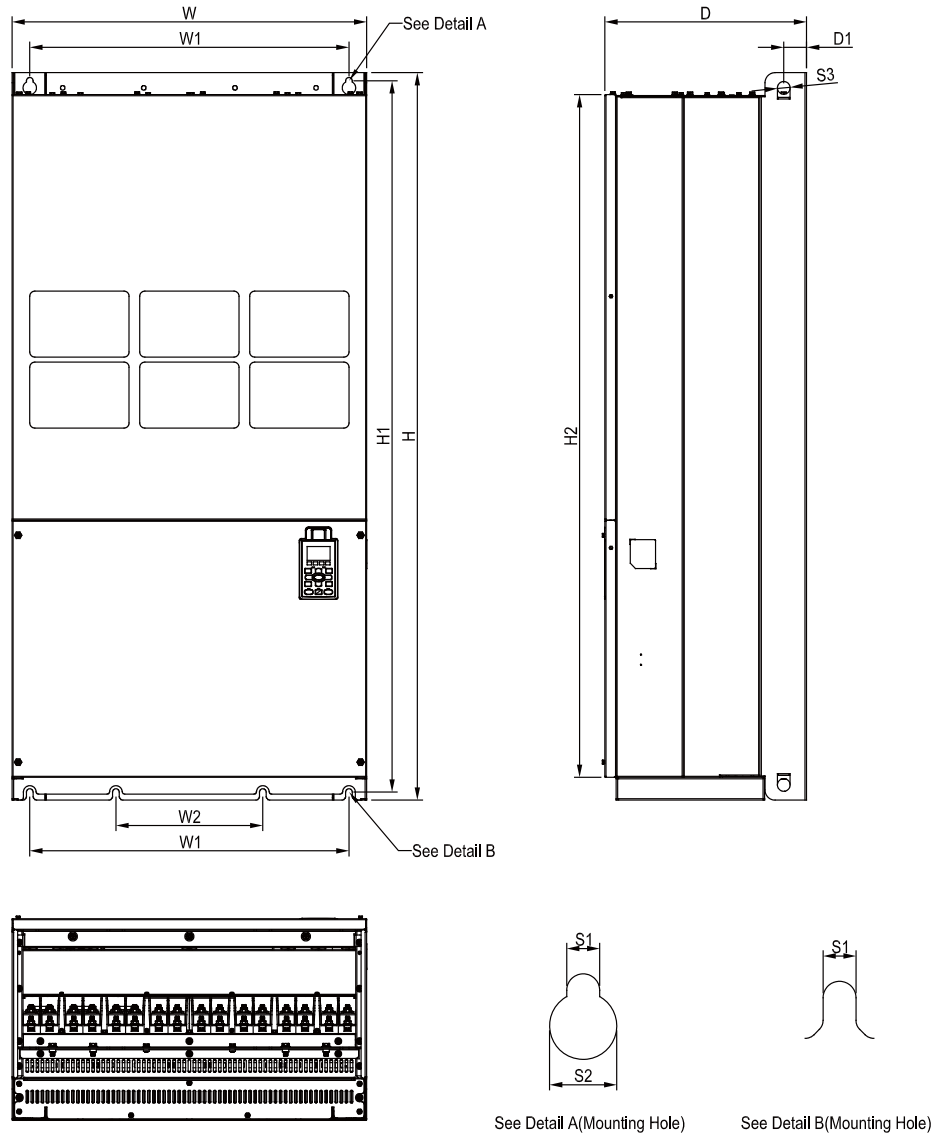

MODEL

VFD2800CH43A-00

Frame	W	H	D	W1	W2	W3	W4	W5	W6	H1	H2	H3	H4
H1	mm	700.0	1435.0	398.0	630.0	290.0	-	-	-	1403.0	1346.0	-	-
	inch	27.56	56.5	15.67	24.8	11.42	-	-	-	55.24	53.02	-	-
Frame	H5	D1	D2	D3	D4	D5	D6	S1	S2	S3	Ø1	Ø2	Ø3
H1	mm	-	45.0	-	-	-	-	13.0	26.5	25.0	-	-	-
	inch	-	1.77	-	-	-	-	0.51	1.04	0.98	-	-	-

Frame H2

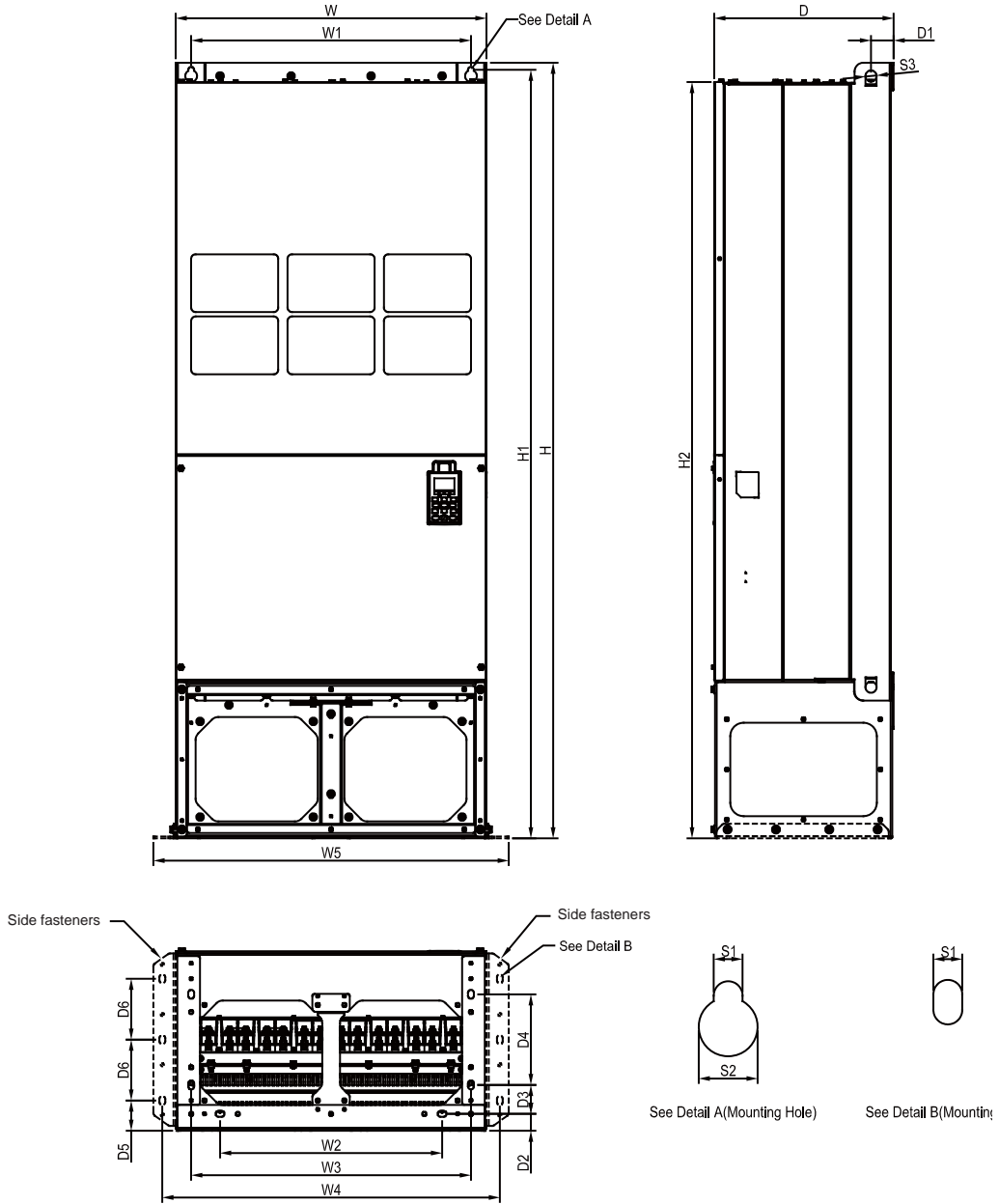

MODEL

VFD2800CH43C-00

Frame		W	H	D	W1	W2	W3	W4	W5	W6	H1	H2	H3	H4
H2	mm	700.0	1745.0	404.0	630.0	500.0	630.0	760.0	800.0	-	1729.0	1701.6	-	-
	inch	27.56	68.70	15.9	24.8	19.69	24.80	29.92	31.50	-	68.07	66.99	-	-
Frame		H5	D1	D2	D3	D4	D5	D6	S1	S2	S3	Ø1	Ø2	Ø3
H2	mm	-	51.0	38.0	65.0	204.0	68.0	137.0	13.0	26.5	25.0	-	-	-
	inch	-	2.0	1.50	2.56	8.03	2.68	5.4	0.51	1.04	0.98	-	-	-

Dimensions

Frame H3

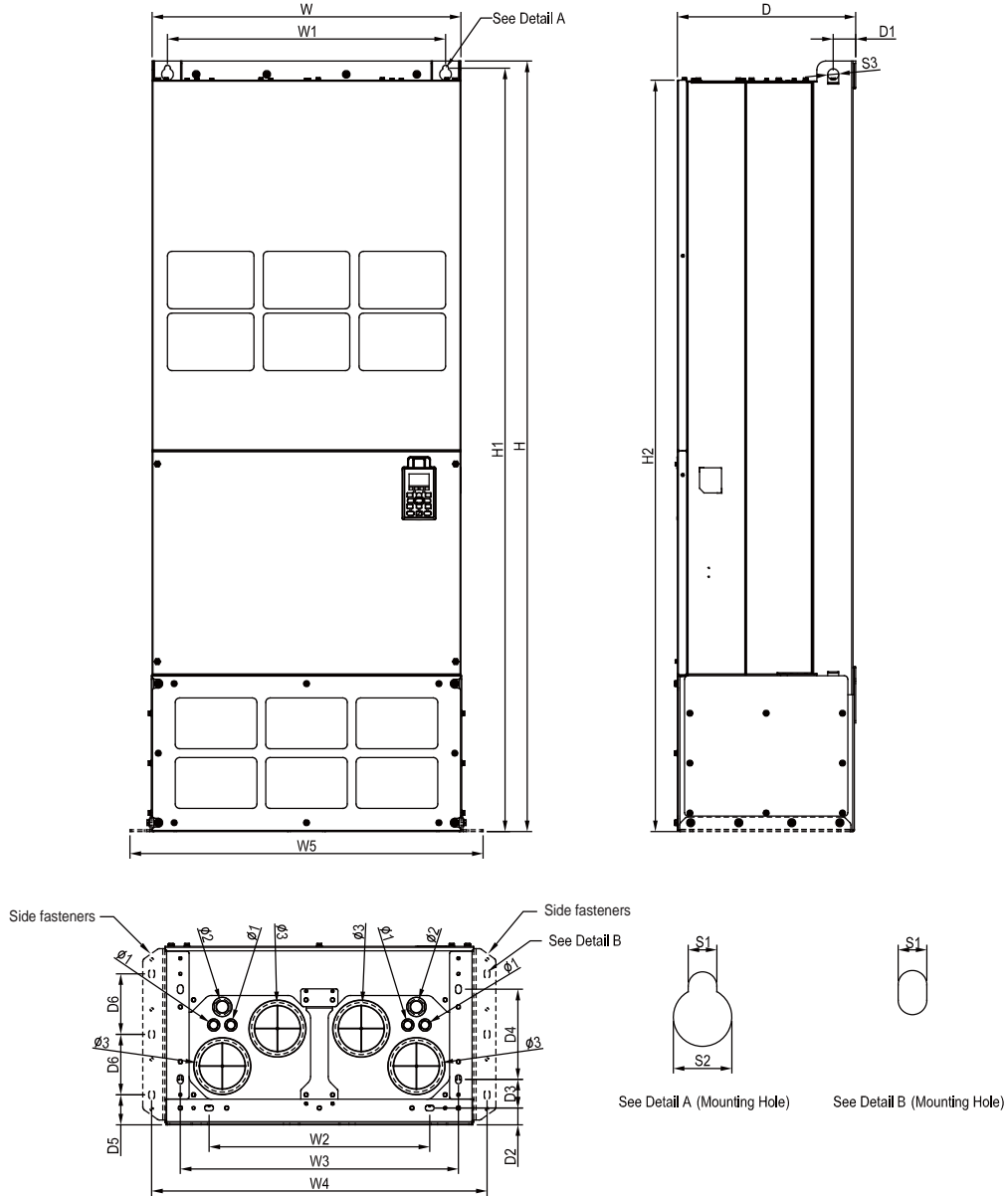

MODEL

VFD2800CH43C-21

Frame	W	H	D	W1	W2	W3	W4	W5	W6	H1	H2	H3	H4	
H3	mm	700.0	1745.0	404.0	630.0	500.0	630.0	760.0	800.0	-	1729.0	1701.6	-	-
	inch	27.56	68.70	15.9	24.80	19.69	24.80	29.92	31.50	-	68.07	66.99	-	-
Frame	H5	D1	D2	D3	D4	D5	D6	S1	S2	S3	Ø1	Ø2	Ø3	
H3	mm	-	51.0	38.0	65.0	204.0	68.0	137.0	13.0	26.5	25.0	22.0	34.0	117.5
	inch	-	2.0	1.50	2.56	8.03	2.68	5.4	0.51	1.04	0.98	0.87	1.34	4.63

Accessories

EMC-PG01L / EMC-PG02L

		Terminals	Description
 <p>Set by Pr.10-00 ~ 10-02</p>	PG1	VP	Output voltage for power: +5V/+12V±5% (use FSW3 to switch +5V/+12V) Max. output current: 200mA
		DCM	Common for power and signal
		A1, /A1 ,B1, /B1, Z1, /Z1	Encoder input signal (Line Driver) Open collector input: +5 V / +24 V (Note1) 1-phase or 2-phase input Max. input frequency: EMC-PG01L: 300KHz; EMC-PG02L: 30KHz
	PG2	A2, /A2, B2, /B2	Pulse input signal (Line Driver or Open Collector) Open collector input: +5V/+24V (Note1) 1-phase or 2-phase input Max. input frequency: EMC-PG01L: 300KHz; EMC-PG02L: 30KHz
	PG OUT	AO, /AO, BO, /BO, ZO, /ZO, SG	PG card output signals. Division frequency function: 1 ~ 255 times Max. output voltage for Line driver: 5V _{DC} Max. output current: 50mA Max. output frequency: EMC-PG01L: 300KHz; EMC-PG02L: 30KHz SG: The GND of PG card is the same as the host controller or PLC, so a common output signal is attained.

EMC-PG010 / EMC-PG020

		Terminals	Description
 <p>Set by Pr.10-00 ~ 10-02</p>	PG1	VP	Output voltage for power: +5V/+12V±5% (use FSW3 to switch +5V/+12V) Max. output current: 200mA
		DCM	Common for power and signal
		A1, /A1 ,B1, /B1, Z1, /Z1	Encoder input signal (Line Driver or Open Collector) Open collector input: +5V/+24V (Note1) 1-phase or 2-phase input Max. input frequency: EMC-PG010: 300KHz; EMC-PG020: 30KHz
	PG2	A2, /A2, B2, /B2	Pulse input signal (Line Driver or Open Collector) Open collector input: +5V/+24V (Note1) 1-phase or 2-phase input Max. input frequency: EMC-PG010: 300KHz; EMC-PG020: 30KHz
	PG OUT	V+, /V-	Needs external power source for PG OUT circuit. Input voltage of power:+12V~+24V
		V-	Negative power supply input
		A/O, B/O, ZO,	PG card output signals. Division frequency function: 1~255 times Add a pull-up resistor to the open collector output signals to avoid signal interferences. [Three pull-up resistors are included in the package (1.8kΩ/1W)] Max. Output current: 20mA Max output frequency: EMC-PG010: 300KHz; EMC-PG020: 30KHz

EMC-PG01R

		Terminals	Description
 <p>Set by Pr.10-00 ~ 10-02</p>	PG1	R1-R2	Resolver output power 7V _{rms} , 10kHz
		S1, S2, S3, S4	Resolver input signal 3.5±0.175V _{rms} , 10kHz
	PG2	A2, /A2, B2, /B2	Pulse input signal (Line Driver or Open Collector) Open collector input: +5V/+24V (Note1) 1-phase or 2-phase input; Max. input frequency: 300KHz
	PG OUT	AO, /AO, BO, /BO, ZO, /ZO, SG	PG card output signals. Division frequency function: 1~255 times Max. output voltage for Line driver: 5V _{DC} Max. output current: 50mA Max. output frequency: 300KHz SG: The GND of PG card is the same as the host controller or PLC, so a common output signal is attained.

Accessories

EMC-PG01U / EMC-PG02U

FJMP1 **S** : Standard UVW Output Encoder; **D** : Delta Encoder

		Terminals	Description
 <p>Set by Pr.10-00 ~ 10-02</p>	PG1	VP	Output voltage for power: +5V/+12V±5% (use FSW3 to switch +5V/+12V) Max. output current: 200mA
		DCM	Common for power and signal
		A1, /A1, B1, /B1, Z1, /Z1	Encoder input signal (Line Driver) 1-phase or 2-phase input. Max. input frequency: 300KHz
		U1, /U1, V1, /V1, W1, /W1	Encoder input signal
	PG2	A2, /A2, B2, /B2	Pulse input signal Open collector input: +5V/+24V (Note1) 1-phase or 2-phase input Max. input frequency: 300KHz
	PG OUT	AO, /AO, BO, /BO, ZO, /ZO, SG	PG card output signals. Division frequency function: 1 ~ 255 times Max. output voltage for Line driver: 5V _{DC} Max. output current: 50mA Max. output frequency: 300KHz SG: The GND of PG card is the same as the host controller or PLC, so a common output signal is attained.

Note 1: For the Open Collector, set input voltage to 5 ~ 15mA and install a pull-up resistor

[5V] Recommend pull-up resistor: 100 ~ 220Ω, 1/2W and above

[12V] Recommend pull-up resistor: 510 ~ 1.35kΩ, 1/2W and above

[24V] Recommend pull-up resistor: 1.8k ~ 3.3kΩ, 1/2W and above

Screw Specifications for Option Card Terminals

EMC-D42A/EMC-D611A EMC-BPS01	Wire gauge	24 ~ 12AWG (0.205 ~ 3.31mm ²)
	Torque	4 Kg-cm [3.47lb-in]
EMC-R6AA	Wire gauge	24 ~ 16AWG (0.205 ~ 1.31mm ²)
	Torque	6 Kg-cm [5.21lb-in]
EMC-PG01L/EMC-PG01O EMC-PG01R/EMC-PG01U	Wire gauge	30 ~ 16AWG (0.0509 ~ 1.31mm ²)
	Torque	2 Kg-cm [1.74lb-in]



EMC-D42A

 I/O Extension Card		Terminals	Description
		COM	Common for multi-function input terminals Select SINK (NPN)/SOURCE (PNP) in J1 jumper/external power supply
MI10 ~ MI13	Refer to parameters 02-26 ~ 02-29 to program the multi-function inputs MI10 ~ MI13. Internal power is applied from terminal E24: +24 V _{DC} ±5% 200mA, 5W External power +24 V _{DC} : max. voltage 30 V _{DC} , min. voltage 19 V _{DC} , 30W ON: the activation current is 6.5mA; OFF: leakage current tolerance is 10μA		
MO10 ~ MO11	Multi-function output terminals (photocoupler) Duty-cycle: 50%; Max. output frequency: 100Hz Max. current: 50mA; Max. voltage: 48 V _{DC}		
MXM	Common for multi-function output terminals MO10, MO11(photocoupler) Max 48 V _{DC} 50mA		

EMC-D611A

 I/O Extension Card		Terminals	Description
		AC	AC power common for multi-function input terminal (Neutral)
MI10 ~ MI15	Refer to Pr. 02.26~Pr. 02.31 for multi-function input selection Input voltage: 100 ~ 130 V _{AC} ; Input frequency: 57 ~ 63 Hz Input impedance: 27Kohm Terminal response time: ON: 10ms; OFF: 20ms		

EMC-R6AA

 Relay Extension Card		Terminals	Description
		RA10 ~ RA15 RC10 ~ RC15	Refer to Pr. 02.36 ~ Pr. 02.41 for multi-function input selection Resistive load: 3A(N.O.)/250 V _{AC} 5A(N.O.)/30 V _{DC} Inductive load (COS 0.4) 2.0A(N.O.)/250 V _{AC} 2.0A(N.O.)/30 V _{DC} It is used to output each monitor signal, such as for drive in operation, frequency attained or overload indication.

EMC-BPS01

 24V Power Shift Card		Terminals	Description
		24V GND	When the AC motor drive power is off, the external power supply card provides external power to the network system, PLC function, and other functions to allow continued operations. Input power: 24 V _{DC} ±5% Maximum input current: 0.5A Note: Do not connect the control terminal +24V (Digital control signal common: SOURCE) directly to the EMC-BPS01 input terminal 24V. Do not connect control terminal GND directly to the EMC-BPS01 input terminal GND.

CMC-MOD01

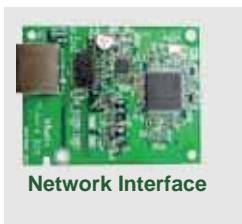

Features

- ▶ MDI/MDI-X auto-detect
- ▶ Supports MODBUS TCP protocol
- ▶ AC motor drive keypad/Ethernet configuration
- ▶ E-mail alarm
- ▶ Baud rate: 10/100Mbps auto-detect
- ▶ Virtual serial port

Network Interface

Interface	RJ-45 with Auto MDI/MDIX	Transmission speed	10/100Mbps Auto-Detect
Number of ports	1 Port	Network protocol	ICMP, IP, TCP, UDP, DHCP, SMTP, MODBUS over TCP/IP, Delta Configuration
Transmission method	IEEE 802.3, IEEE 802.3u		
Transmission cable	Category 5e shielding 100M		

Accessories

▪ CMC-EIP01

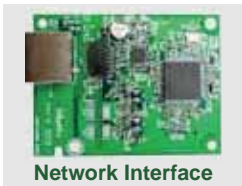

Network Interface

Features

- ▶ MDI/MDI-X auto-detect
- ▶ Supports MODBUS TCP and Ethernet/IP protocol
- ▶ Baud rate: 10/100Mbps auto-detect
- ▶ AC motor drive keypad/Ethernet configuration
- ▶ Virtual serial port t

Network Interface

Interface	RJ-45 with Auto MDI/MDIX	Transmission speed	10/100 Mbps Auto-Detect
Number of ports	1 Port	Network protocol	ICMP, IP, TCP, UDP, DHCP, SMTP, MODBUS over TCP/IP, Delta Configuration
Transmission method	IEEE 802.3, IEEE 802.3u		
Transmission cable	Category 5e shielding 100M		

▪ CMC-PD01



Features

- ▶ Supports PZD control data exchange
- ▶ Supports PKW polling AC motor drive parameters
- ▶ Supports user diagnosis function
- ▶ Auto-detects baud rates; supports Max. 12Mbps

PROFIBUS DP Connector

Interface	DB9 connector
Transmission method	High-speed RS-485
Transmission cable	Shielded twisted pair cable
Electrical isolation	500V _{DC}

Communication

Message type	Cyclic data exchange
Module name	CMC-PD01
GSD document	DELA08DB.GSD
Company ID	08DB (HEX)
Serial transmission speed supported (auto-detection)	9.6kbps; 19.2kbps; 93.75kbps; 187.5kbps; 125kbps; 250kbps; 500kbps; 1.5Mbps; 3Mbps; 6Mbps; 12Mbps (bit per second)

▪ CMC-DN01



Features

- ▶ Based on the high-speed communication interface of Delta HSSP protocol, able to conduct immediate control of an AC motor drive
- ▶ Supports Group 2 only connection and polling I/O data exchange
- ▶ For I/O mapping, supports Max. 32 words of input and 32 words of output
- ▶ Supports EDS file configuration in DeviceNet configuration software
- ▶ Supports all baud rates on DeviceNet bus: 125 kbps, 250 kbps, 500 kbps and extendable serial transmission speed mode
- ▶ Node address and serial transmission speed can be set up on AC motor drive
- ▶ Power supplied from AC motor drive

DeviceNet Connector

Interface	5-Pin 5.08mm pluggable connector
Transmission method	CAN
Transmission cable	Shielded twisted pair cable (with 2 power cables)
Transmission speed	125kbps, 250kbps, 500kbps and extendable serial transmission speed mode
Network protocol	DeviceNet protocol

DeviceNet Connector

Interface	50 PIN communication terminal
Transmission method	SPI communication
Terminal function	1. Communicating with AC motor drive 2. Transmitting power supply from AC motor drive
Communication protocol	Delta HSSP protocol

▪ EMC-COP01

RJ-45 Pin definition

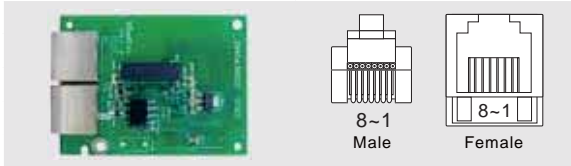

Pin	Pin name	Definition
1	CAN_H	CAN_H bus line (dominant high)
2	CAN_L	CAN_L bus line (dominant low)
3	CAN_GND	Ground/0V/V-
6	CAN_GND	Ground/0V/V-

Network Interface

Interface	RJ-45
Number of ports	1 Port
Transmission method	CAN
Transmission cable	CAN standard cable
Transmission speed	1M 500k 250k 125k 100k 50k
Communication protocol	CANopen

▪ CANopen Communication Cable

Model: TAP-CB05, TAP-CB10

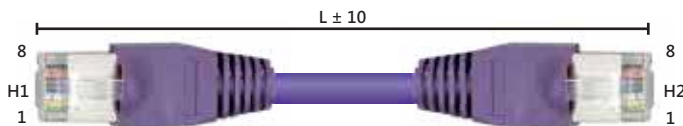

Title	Part No.	L	
		mm	inch
1	UC-CMC003-01A	300	11.8
2	UC-CMC005-01A	500	19.6
3	UC-CMC010-01A	1000	39
4	UC-CMC015-01A	1500	59
5	UC-CMC020-01A	2000	78.7
6	UC-CMC030-01A	3000	118.1
7	UC-CMC050-01A	5000	196.8
8	UC-CMC100-01A	10000	393.7
9	UC-CMC200-01A	20000	787.4

▪ Digital Keypad Accessories: RJ45 Extension

Applicable Models: CBC-K3FT, CBC-K5FT, CBC-K7FT, CBC-K10FT, CBC-K16FT

Title	Part No.	Explanation
1	CBC-K3FT	RJ45 extension lead, 3 feet (approximately 0.9m)
2	CBC-K5FT	RJ45 extension lead, 5 feet (approximately 1.5m)
3	CBC-K7FT	RJ45 extension lead, 7 feet (approximately 2.1m)
4	CBC-K10FT	RJ45 extension lead, 10 feet (approximately 3m)
5	CBC-K16FT	RJ45 extension lead, 16 feet (approximately 4.9m)

▪ CANopen Breakout Box

Model: TAP-CN03

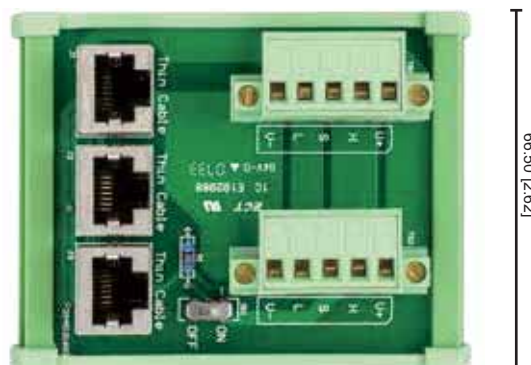

Ordering Information

Frame Size		Power Range	Models		
Frame A		230V: 0.75 kW ~ 3.7 kW 460V: 0.75 kW ~ 5.5 kW	VFD007CH 23A-21 VFD015CH 23A-21 VFD022CH 23A-21 VFD037CH 23A-21	VFD007CH 43A-21 VFD015CH 43A-21 VFD022CH 43A-21 VFD037CH 43A-21 VFD055CH 43A-21	VFD007CH 4EA-21 VFD015CH 4EA-21 VFD022CH 4EA-21 VFD037CH 4EA-21 VFD055CH 4EA-21
Frame B		230V: 5.5 kW ~ 11 kW 460V: 7.5 kW ~ 15 kW	VFD055CH 23A-21 VFD075CH 23A-21 VFD110CH 23A-21	VFD075CH 43A-21 VFD110CH 43A-21 VFD150CH 43A-21	VFD075CH 4EA-21 VFD110CH 4EA-21 VFD150CH 4EA-21
Frame C		230V: 15 kW ~ 18.5 kW 460V: 18.5 kW ~ 30 kW	VFD150CH 23A-21 VFD185CH 23A-21	VFD185CH 43A-21 VFD220CH 43A-21 VFD300CH 43A-21	VFD185CH 4EA-21 VFD220CH 4EA-21 VFD300CH 4EA-21
Frame D		230V: 22 kW ~ 37 kW 460V: 37 kW ~ 75 kW	Frame D1:	Frame D2:	Frame D0-2:
			VFD220CH 23A-00 VFD300CH 23A-00 VFD370CH 23A-00 VFD450CH 43A-00 VFD550CH 43A-00 VFD750CH 43A-00	VFD220CH 23A-21 VFD300CH 23A-21 VFD370CH 23A-21 VFD450CH 43A-21 VFD550CH 43A-21 VFD750CH 43A-21	VFD370CH 43S-21
Frame E		230V: 45 kW ~ 55 kW 460V: 90 kW ~ 110 kW	Frame E1:	Frame E2:	
			VFD450CH 23A-00 VFD550CH 23A-00 VFD900CH 43A-00 VFD1100CH 43A-00	VFD450CH 23A-21 VFD550CH 23A-21 VFD900CH 43A-21 VFD1100CH 43A-21	
Frame F		230V: 75 kW 400V: 132 kW	Frame F1:	Frame F2:	
			VFD750CH 23A-00 VFD1320CH 43A-00	VFD750CH 23A-21 VFD1320CH 43A-21	
Frame G		460V: 160 kW ~ 220 kW	Frame G1:	Frame G2:	
			VFD1600CH 43A-00 VFD1850CH 43A-00 VFD2200CH 43A-00	VFD1600CH 43A-21 VFD1850CH 43A-21 VFD2200CH 43A-21	

Frame Size		Power Range	Models		
Frame H		460V: 280 kW	Frame H1:	Frame H2:	Frame H3:
			VFD2800CH 43A-00	VFD2800CH 43C-00	VFD2800CH 43C-21

Model Name Explanation

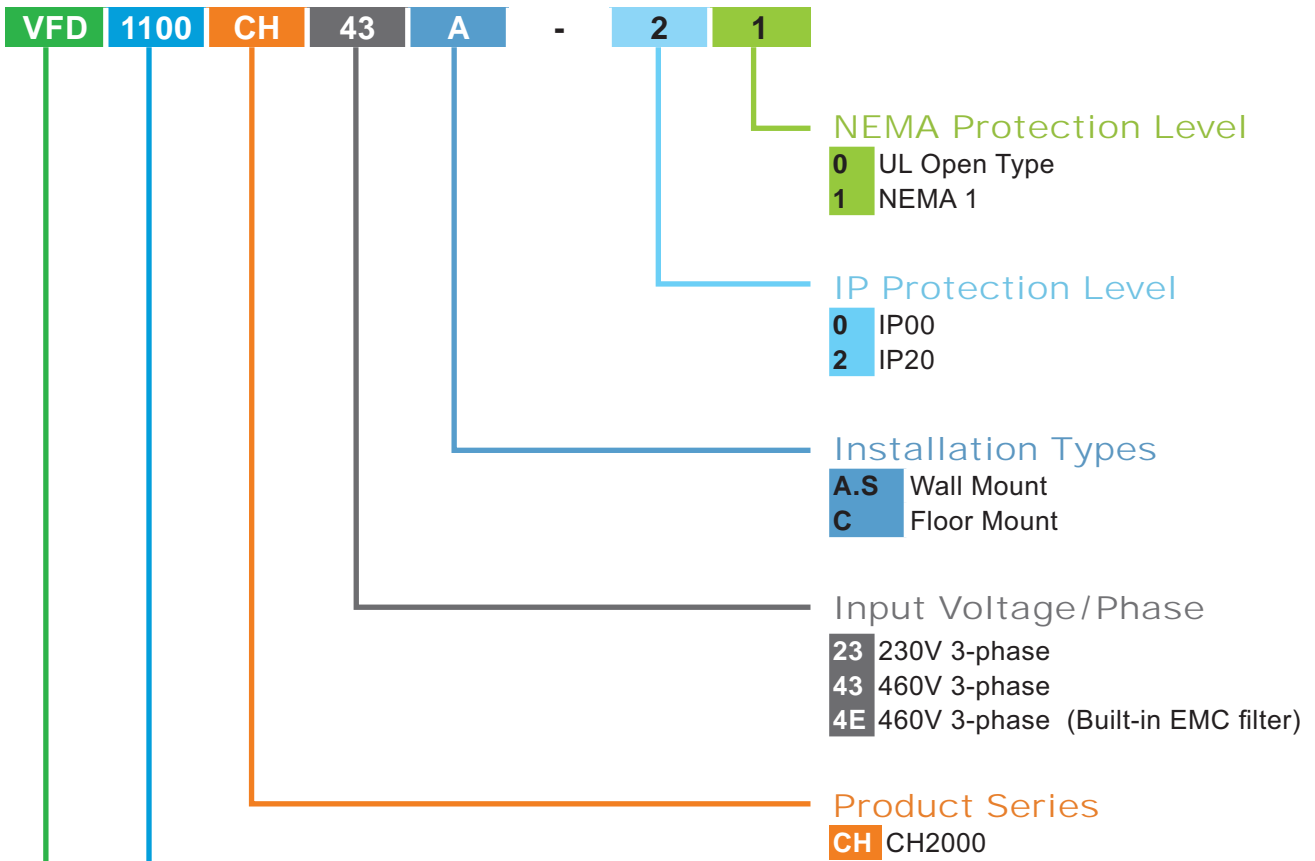

Applicable Motor Capacity

007	0.75 kW	075	7.5 kW	300	30 kW	900	90 kW	2200	220 kW
015	1.5 kW	110	11 kW	370	37 kW	1100	110 kW	2800	280 kW
022	2.2 kW	150	15 kW	450	45 kW	1320	132 kW		
037	3.7 kW	185	18.5 kW	550	55 kW	1600	160 kW		
055	5.5 kW	220	22 kW	750	75 kW	1850	180 kW		

Product
Variable Frequency Drive

Global Operations

ASIA (Taiwan)



Taoyuan Technology Center (Green Building)



Taoyuan Plant 1



Taoyuan Plant (Diamond-rated Green Building)

ASIA (China)



Wujiang Plant 3



Delta Electronics

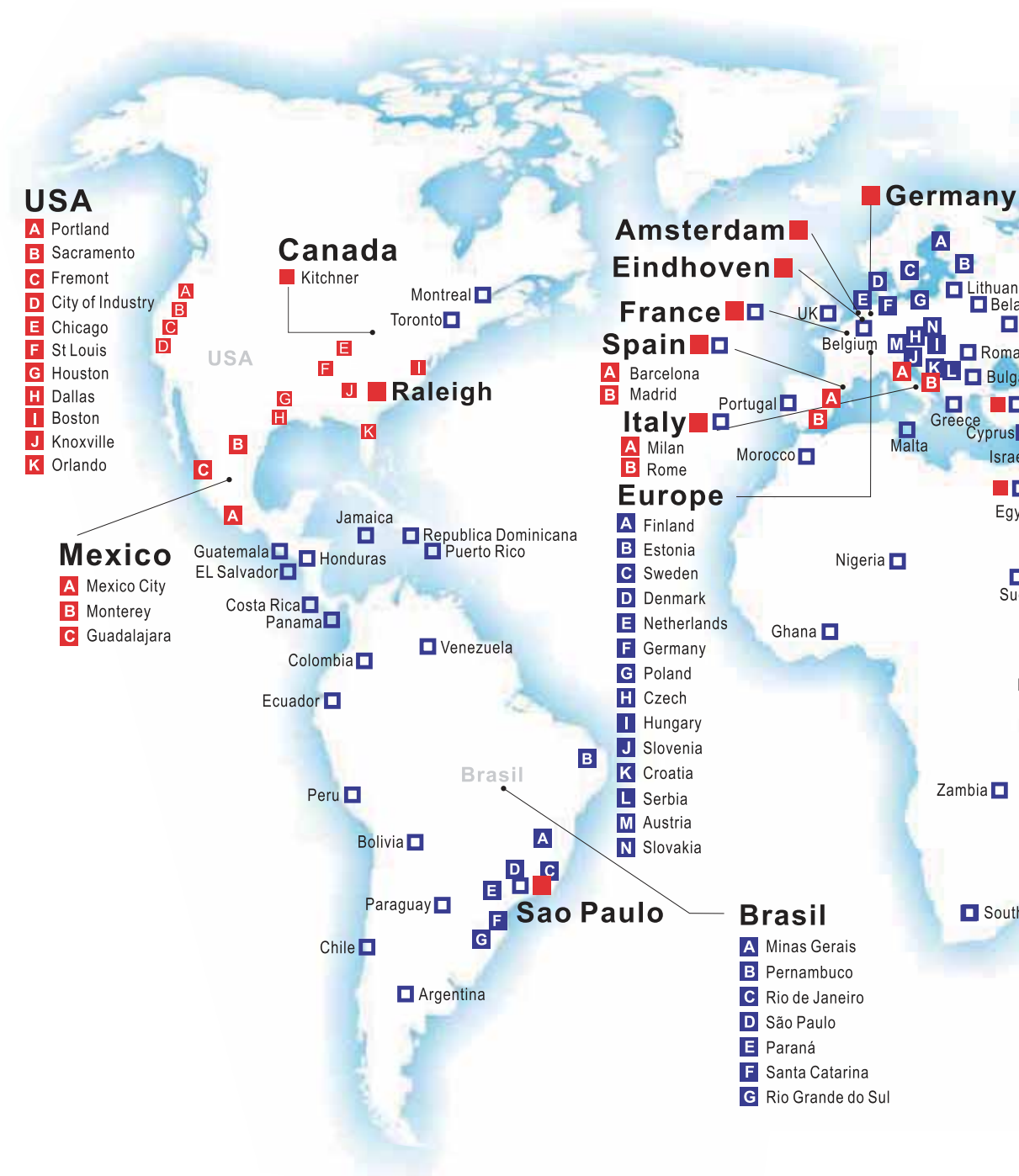

ASIA (Japan)



Tokyo Office

ASIA (India)



Rudrapur Plant
(Green Building)

EUROPE



Amsterdam, Netherlands

AMERICA



Research Triangle Park

▲ Factories 4 ■ Branch Offices 89 ● R&D Centers 5 ■ Distributors 635





Smarter. Greener. Together.

Industrial Automation Headquarters

Delta Electronics, Inc.

Taoyuan Technology Center
No.18, Xinglong Rd., Taoyuan City,
Taoyuan County 33068, Taiwan
TEL: 886-3-362-6301 / FAX: 886-3-371-6301

Asia

Delta Electronics (Jiangsu) Ltd.

Wujiang Plant 3
1688 Jiangxing East Road,
Wujiang Economic Development Zone
Wujiang City, Jiang Su Province,
People's Republic of China (Post code: 215200)
TEL: 86-512-6340-3008 / FAX: 86-769-6340-7290

Delta Greentech (China) Co., Ltd.

238 Min-Xia Road, Pudong District,
ShangHai, P.R.C.
Post code : 201209
TEL: 86-21-58635678 / FAX: 86-21-58630003

Delta Electronics (Japan), Inc.

Tokyo Office
2-1-14 Minato-ku Shibadaimon,
Tokyo 105-0012, Japan
TEL: 81-3-5733-1111 / FAX: 81-3-5733-1211

Delta Electronics (Korea), Inc.

1511, Byucksan Digital Valley 6-cha, Gasan-dong,
Geumcheon-gu, Seoul, Korea, 153-704
TEL: 82-2-515-5303 / FAX: 82-2-515-5302

Delta Electronics Int'l (S) Pte Ltd

4 Kaki Bukit Ave 1, #05-05, Singapore 417939
TEL: 65-6747-5155 / FAX: 65-6744-9228

Delta Electronics (India) Pvt. Ltd.

Plot No 43 Sector 35, HSIDC
Gurgaon, PIN 122001, Haryana, India
TEL : 91-124-4874900 / FAX : 91-124-4874945

Americas

Delta Products Corporation (USA)

Raleigh Office
P.O. Box 12173, 5101 Davis Drive,
Research Triangle Park, NC 27709, U.S.A.
TEL: 1-919-767-3800 / FAX: 1-919-767-8080

Delta Greentech (Brasil) S.A

Sao Paulo Office
Rua Itapeva, 26 - 3° andar Edificio Itapeva One-Bela Vista
01332-000-São Paulo-SP-Brazil
TEL: +55 11 3568-3855 / FAX: +55 11 3568-3865

Europe

Delta Electronics (Netherlands) B.V.

Eindhoven Office
De Witbogt 20, 5652 AG Eindhoven, The Netherlands
TEL: +31 (0)40-8003800 / FAX: +31 (0)40-8003898

*We reserve the right to change the information in this catalogue without prior notice.