

Autonics Built-in BRAKE TYPE 5-PHASE STEPPER MOTOR INSTRUCTION MANUAL

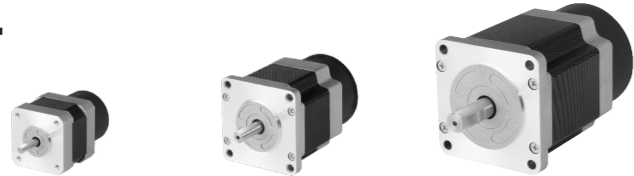

[Frame size 42mm] [Frame size 60mm] [Frame size 85mm]
Thank you for choosing our Autonics product.
Please read the following safety considerations before use.

Safety Considerations

- ⚠ Please observe all safety considerations for safe and proper product operation to avoid hazards.
- ⚠ symbol represents caution due to special circumstances in which hazards may occur.
- Warning** Failure to follow these instructions may result in serious injury or death.
- Caution** Failure to follow these instructions may result in personal injury or product damage.
- Warning**
 - Fail-safe device must be installed when using the unit with machinery that may cause serious injury or substantial economic loss.** (e.g. nuclear power control, medical equipment, ships, vehicles, railways, aircraft, combustion apparatus, safety equipment, crime/disaster prevention devices, etc.) Failure to follow this instruction may result in fire, personal injury, or economic loss.
 - Do not use the brake for safety.** Failure to follow this instruction may result in personal injury, or product and ambient equipment damage.
 - Fix the unit on the metal plate.** Failure to follow this instruction may result in personal injury, or product and ambient equipment damage.
 - Do not connect, repair, or inspect the unit while connected to a power source.** Failure to follow this instruction may result in fire.
 - Install the unit after considering counter plan against power failure.** Failure to follow this instruction may result in personal injury, or economic loss.
 - Check 'Connections' before wiring.** Failure to follow this instruction may result in fire.
 - Do not disassemble or modify the unit.** Failure to follow this instruction may result in electric shock or fire.
 - Install the motor in the housing or ground it.** Failure to follow this instruction may result in electronic shock, fire, or personal injury.
 - Make sure to install covers on motor rotating components.** Failure to follow this instruction may result in personal injury.
 - Do not touch the unit during or after operation for a while.** Failure to follow this instruction may result in burn due to high temperature of the surface.
 - Turn OFF the power directly when error occurs.** Failure to follow this instruction may result in electric shock, fire, or personal injury.

Caution

- Use the unit within the rated specifications.** Failure to follow this instruction may result in fire or product damage.
- Use dry cloth to clean the unit, and do not use water or organic solvent.** Failure to follow this instruction may result in fire.
- Do not use the unit in the place where flammable/explosive/corrosive gas, humidity, direct sunlight, radiant heat, vibration, impact, or salinity may be present.** Failure to follow this instruction may result in fire or explosion.
- The motor may overheat depending on the environment.** Install the unit at the well-ventilated environment and forced cooling with a cooling fan. Failure to follow this instruction may result in product damage and degradation.

Ordering Information

A 8K-M 5 6 6 - B	Motor type	B	Built-in brake type
	Wire connection	No mark	Pentagon
	Motor length	S ^{*1}	Standard
	Motor frame size	4	42×42mm
		3	33mm
		4	39mm
	6	5	47mm
		4	48.5mm
		6	59.5mm
	9	9	89mm
		6	68mm
		9	98mm
	13	6	68mm
		13	128mm
	Motor phase	5	5-phase
	Rated current	S	0.75 A/Phase
		M	1.4 A/Phase
		G	2.8 A/Phase
	Max. holding torque	Square	kgf-cm (Refer to motor specification)
		A	Autonics motor

※Standard wiring is optional.
※The above specifications are subject to change and some models may be discontinued without notice.
※Be sure to follow cautions written in the instruction manual and the technical descriptions (catalog, homepage).

Specifications

Frame size 42mm			
Model	A1K-S543-B	A2K-S544-B	A3K-S545-B
Max. holding torque ^{*1}	1.3 kgf-cm (0.13 N-m)	1.8 kgf-cm (0.18 N-m)	2.4 kgf-cm (0.24 N-m)
Rotor moment of inertia	35 g-cm ² (35×10 ⁻⁷ kg-m ²)	54 g-cm ² (54×10 ⁻⁷ kg-m ²)	68 g-cm ² (68×10 ⁻⁷ kg-m ²)
Rated current	0.75 A/Phase		
Basic step angle	0.72° / 0.36° (Full/Half step)		
Rated excitation voltage	24VDC±10%		
Rated excitation current	0.2A		
Static friction torque	1.8kgf-cm		
Rotation part inertia	3×10 ⁻⁷ kg-cm ²		
Insulation class	B type (130°C)		
B type brake	Power on: brake is released, power off: brake is operating		
Operating time	Max. 25ms		
Releasing time	Max. 15ms		
Weight ^{*2}	Approx. 0.44kg (approx. 0.39kg)	Approx. 0.49kg (approx. 0.44kg)	Approx. 0.59kg (approx. 0.54kg)

Frame size 60mm						
Model	A4K-S564-B	A4K-M564-B	A8K-S566-B	A8K-M566-B	A16K-M569-B	A16K-G569-B
Max. holding torque ^{*1}	4.2 kgf-cm (0.41 N-m)	4.2 kgf-cm (0.41 N-m)	8.3 kgf-cm (0.81 N-m)	8.3 kgf-cm (0.81 N-m)	16.6 kgf-cm (1.63 N-m)	16.6 kgf-cm (1.63 N-m)
Rotor moment of inertia	175 g-cm ² (175×10 ⁻⁷ kg-m ²)	175 g-cm ² (175×10 ⁻⁷ kg-m ²)	280 g-cm ² (280×10 ⁻⁷ kg-m ²)	280 g-cm ² (280×10 ⁻⁷ kg-m ²)	560 g-cm ² (560×10 ⁻⁷ kg-m ²)	560 g-cm ² (560×10 ⁻⁷ kg-m ²)
Rated current	0.75 A/Phase 1.4A/Phase		0.75 A/Phase 1.4A/Phase		1.4A/Phase 2.8A/Phase	
Basic step angle	0.72° / 0.36° (Full/Half step)					
Rated excitation voltage	24VDC±10%					
Rated excitation current	0.33A					
Static friction torque	8kgf-cm					
Rotation part inertia	29×10 ⁻⁷ kg-cm ²					
Insulation class	B type (130°C)					
B type brake	Power on: brake is released, power off: brake is operating					
Operating time	Max. 25ms					
Releasing time	Max. 20ms					
Weight ^{*2}	Approx. 1.03kg (approx. 0.95kg)	Approx. 1.03kg (approx. 0.95kg)	Approx. 1.33kg (approx. 1.25kg)	Approx. 1.33kg (approx. 1.25kg)	Approx. 1.73kg (approx. 1.65kg)	Approx. 1.73kg (approx. 1.65kg)

Frame size 85mm						
Model	A21K-M596-B	A21K-G596-B	A41K-M599-B	A41K-G599-B	A63K-M5913-B	A63K-G5913-B
Max. holding torque ^{*1}	21 kgf-cm (2.1 N-m)	21 kgf-cm (2.1 N-m)	41 kgf-cm (4.0 N-m)	41 kgf-cm (4.0 N-m)	63 kgf-cm (6.2 N-m)	63 kgf-cm (6.2 N-m)
Rotor moment of inertia	1,400 g-cm ² (1,400×10 ⁻⁷ kg-m ²)	1,400 g-cm ² (1,400×10 ⁻⁷ kg-m ²)	2,700 g-cm ² (2,700×10 ⁻⁷ kg-m ²)	2,700 g-cm ² (2,700×10 ⁻⁷ kg-m ²)	4,000 g-cm ² (4,000×10 ⁻⁷ kg-m ²)	4,000 g-cm ² (4,000×10 ⁻⁷ kg-m ²)
Rated current	1.4A/Phase 2.8A/Phase		1.4A/Phase 2.8A/Phase		1.4A/Phase 2.8A/Phase	
Basic step angle	0.72° / 0.36° (Full/Half step)					
Rated excitation voltage	24VDC±10%					
Rated excitation current	0.62A					
Static friction torque	40kgf-cm					
Rotation part inertia	153×10 ⁻⁷ kg-cm ²					
Insulation class	B type (130°C)					
B type brake	Power on: brake is released, power off: brake is operating					
Operating time	Max. 60ms					
Releasing time	Max. 15ms					
Weight ^{*2}	Approx. 2.74kg (approx. 2.64kg)	Approx. 2.74kg (approx. 2.64kg)	Approx. 3.84kg (approx. 3.74kg)	Approx. 3.84kg (approx. 3.74kg)	Approx. 4.84kg (approx. 4.74kg)	Approx. 4.84kg (approx. 4.74kg)

※1: Max. holding torque is maintenance torque in stopping the motor when supply the rated current and is standard method for comparing the performance of motors.
※2: The weight includes packaging. The weight in parenthesis is for unit only.

Common specifications

Insulation class	B type (130°C)
Insulation resistance	Over 100MΩ (at 500VDC megger) between motor coil-case
Dielectric strength	1 kVAC 50/60Hz for 1 min between motor coil-case
Temperature rise	5-phase excitation for rated current, below 80°C at stopped (resistance method)
Environment	Ambient temp. -10 to 50°C, storage: -25 to 85°C Ambient humi. 35 to 85%RH, storage: 35 to 85%RH
Stop angle error ^{*1}	±3' (±0.05°)
Shaft vibration ^{*2}	0.05mm T.I.R.
Radial movement ^{*3}	Max. 0.025mm (Load 5N)
Axial movement ^{*4}	Max. 0.075mm (Load 10N)
Concentricity for shaft of set-up in-low	0.075mm T.I.R.
Perpendicularity of set-up plate shaft	0.075mm T.I.R.
Protection structure	IP30 (IEC34-5 standard)

※1: Specifications are for full-step angle, with no-load (values may vary by load size.)
※2: T.I.R.(Total Indicator Reading) - The difference between the maximum and minimum readings of a dial gauge during one complete revolution of monitored reference.

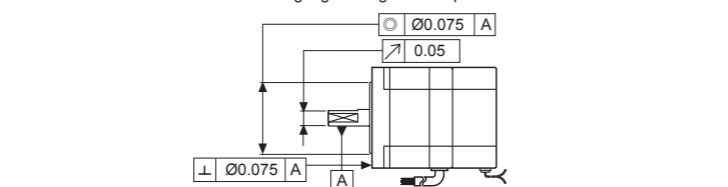

※3: Amount of radial shaft displacement when adding a radial load (5N) to the tip of the motor shaft.
※4: Amount of axial shaft displacement when adding a axial load (10N) to the shaft.
※Rotation direction of the Motor and the Gear Head output axis is same.
※Environment resistance is rated at no freezing or condensation.

Dimensions

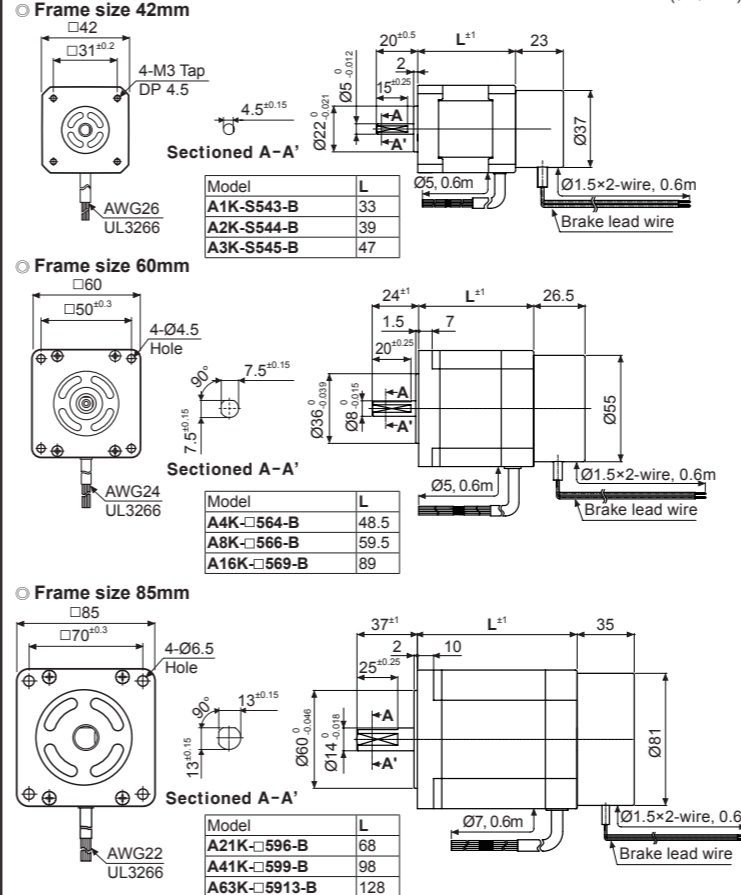

Connection Diagram

Autonics 5-phase stepper motors use pentagon wiring methods. Therefore, it is a proper product for the 5-phase stepper motor driver which is working as a bipolar pentagon driving method.

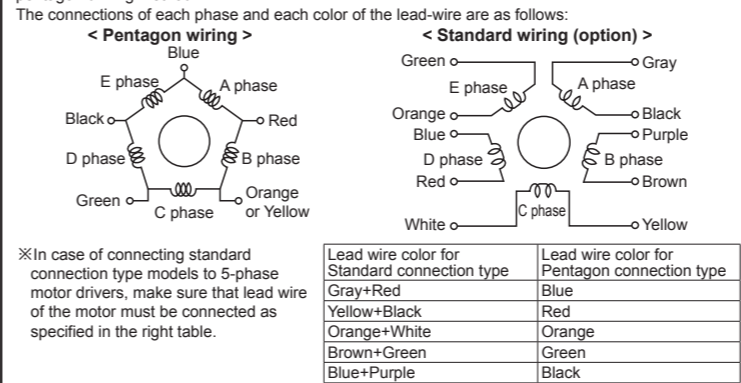

Installation

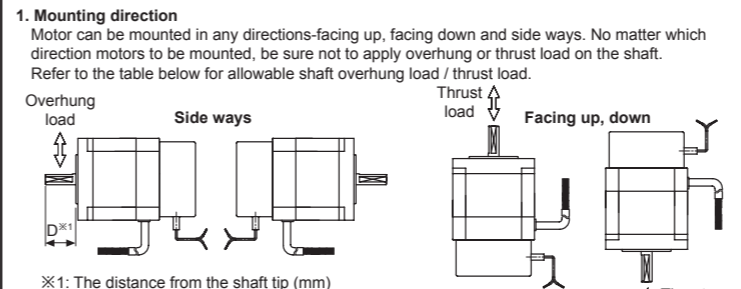

Motor size	The distance from the shaft in front (mm), Allowable overhung load [kgf (N)]					Allowable thrust load [kgf (N)]
	D=0	D=5	D=10	D=15	D=20	
Frame size 42mm	2 (20)	2.5 (25)	3.4 (33)	5.2 (51)	—	5 (49)
Frame size 60mm	6.3 (62)	7.5 (74)	9.5 (93)	13 (127)	19 (186)	10 (98)
Frame size 85mm	26 (255)	29 (284)	34 (333)	39 (382)	48 (470)	30 (294)

Do not apply excessive force on motor cable when mounting motors. Do not forcibly pull or insert the cable. It may cause poor connection or disconnection of the cable. In case of frequent cable movement required application, proper safety countermeasures must be ensured.

2. Motor mounting

With considering heat radiation and vibration isolation, mount the motor as tight as possible against a metal panel having high thermal conductivity such as iron or aluminum. When mounting motors, use hexagon socket screws, spring washers and flat washers. Refer to the table below for allowable thickness of mounting plate and using bolt.

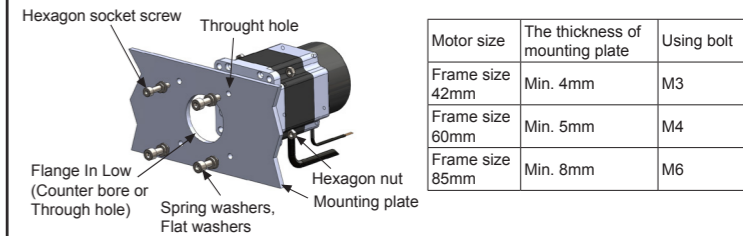

3. Connection with load

When connecting the load, be sure of alignment of the center, tension of the belt, and parallel of the pulley. When connecting the load such as a pulley or a belt, be cautious of the allowable thrust load, radial load, and shock, as well as tighten the screw for a coupling or a pulley not to be unscrewed. When attach a coupling or a pulley to the shaft, be cautious of damage on shaft or bearings and it is banned to disassemble or change structure of the device or the shaft for connecting with a load. Please contact us if necessary.

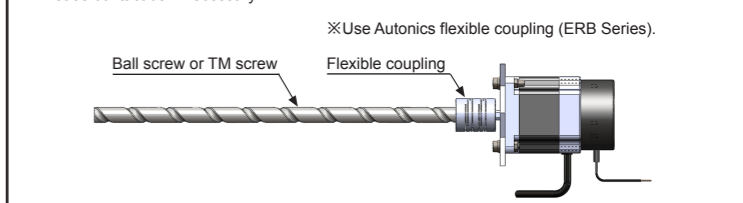

When connecting a load such as Ball screw or Tm screw directly to the shaft of the motor, use flexible coupling as image showing above. If the center of the load and the shaft is not aligned, it may cause severe vibration, damage on shaft or shortened life cycle of bearings.

- 4. Installation condition**
- Install the motor in a place that meets certain conditions specified below. It may cause product damage if instructions are not following.
- The inner housing installed indoor
 - (This unit is manufactured and designed for attaching to equipment. Install a ventilation device.)
 - Within -10 to 50°C (at non-freezing status) of ambient temperature
 - Within 35 to 85%RH (at non-dew status) of ambient humidity
 - The place without explosive, flammable and corrosive gas
 - The place without direct ray of light
 - The place where dust or metal scrap does not enter into the unit
 - The place without contact with water, oil, or other liquid
 - The place without contact with strong alkali or acid material
 - The place where easy heat dissipation could be made
 - The place where no continuous vibration or severe shock
 - The place with less salt content
 - The place with less electronic noise occurs by welding machine, motor, etc.
 - The place where radioactive substances and magnetic fields does not exist and is not in the vacuum status

Cautions during Use

- Follow instructions in 'Cautions during Use'. Otherwise, It may cause unexpected accidents.
- Using motors at low temperature may cause reducing ball bearing's grease consistency and friction torque is increased. Start the motor in a steady manner since motor's torque is not to be influenced.
- When power is supplied or not to the brake, the unit may occur clack sound.
- When drive the motor, supply power to electro-magnetic brake for releasing the brake. When the brake pad is worn out, the product life cycle is shorten, the rated static friction torque is reduced.
- For using motor, it is recommended to maintenance and inspection regularly.
 - Unwinding bolts and connection parts for the unit installation and load connection
 - Strange sound from ball bearing of the unit
 - Damage and stress of lead cable of the unit
 - Connection error with driver
 - Inconsistency between the axis of motor output and the center, concentric (eccentric, declination) of the load, etc.
- This unit may be used in the following environments.
 - Indoors (in the environment condition rated in 'Specifications')
 - Altitude max. 2,000m
 - Pollution degree 2
 - Installation category II

Major Products

- Photoelectric Sensors
 - Fiber Optic Sensors
 - Door Sensors
 - Door Side Sensors
 - Area Sensors
 - Proximity Sensors
 - Pressure Sensors
 - Rotary Encoders
 - Connectors/Sockets
 - Switching Mode Power Supplies
 - Control Switches/Lamps/Buzzers
 - I/O Terminal Blocks & Cables
 - Stepper Motors/Drivers/Motion Controllers
 - Graphic/Logic Panels
 - Field Network Devices
 - Laser Marking System (Fiber, CO₂, Nd: YAG)
 - Laser Welding/Cutting System
 - Temperature Controllers
 - Temperature/Humidity Transducers
 - SSRs/Power Controllers
 - Counters
 - Timers
 - Panel Meters
 - Tachometer/Pulse (Rate) Meters
 - Display Units
 - Sensor Controllers
- Autonics Corporation**
http://www.autonics.com
- HEADQUARTERS:
18, Bansong-ro 513 beon-gil, Haeundae-gu, Busan, South Korea, 48002
TEL: 82-51-519-3232
E-mail: sales@autonics.com